

APHS *news*

Summer 2023



Ofsted
Good
Provider



LEARNING TO MAKE THE DIFFERENCE

W: www.aldermanpeel.norfolk.sch.uk



AldermanPeelHigh



@AldermanHigh

Principal's Letter



Welcome to our 60+ page bumper edition of the APHS newsletter! This edition highlights the level of ambition shown by our staff to offer the best possible quality of education and personal development for our students. The result has been a phenomenal term packed with achievements.

Throughout the year, it has been a real privilege to go into lessons to see well-behaved students being well-taught by expert staff on a daily basis. There are lots of examples of the high-quality work that students have produced and the pride that they have shown in their progress. These daily experiences in combination with the exceptional opportunities outlined in this newsletter have undoubtedly brought a great deal of happiness to students, parents and staff. Always so important.

I would like to take this opportunity to thank all of the hardworking staff at APHS for all that they have contributed to the success of APHS throughout this year. It has been wonderful to welcome Mrs Jagger (Receptionist), Mrs Ryder (Data Manager) and Mr Shaw (Caretaker) to the APHS family and see the outstanding start they have made in their roles. Mr Sutton has also been promoted to Site Manager and has revolutionised the role. It has also been wonderful to welcome back Mrs Fray (Teacher of History and Psychology) from maternity leave, and also see Mrs Light (Teacher of Art) make a full return to work following long-term illness.

Sadly, we also need to say goodbye to a number of members of staff at this time.

Mrs Murkin (Head of English) will be leaving at the end of this year. Therefore, Mrs Doyle and Mr Brailsford (from Hellesdon High School) have been promoted to the role of Co-Heads of English. We are very excited by their plans to take the department forward and we wish Mrs Murkin all the best as she progresses into a new leadership challenge.

Mrs Wagg and Mr Leverton are also leaving to take up teaching positions at another school. We have appointed Mr Gillen and Mrs Shooter who will be fulfilling the roles of Teachers of English. Mrs Golding-Searle will also be stepping into a full-time role as Teacher of English. A fantastic team.

Mr Murkin and Mr Beaumont will also be leaving to take up teaching positions at different schools. Mrs De Grandis will also be leaving, having completed her teaching apprenticeship and gaining qualified teacher status. We are delighted to have appointed Mr Coe, Mr Whitaker and to welcome back Mr Collyer to the Maths Department. Mrs Long will also be taking a greater role in the teaching of Maths next year. In combination with Mr Boyce and Mrs Barker, this is an exciting time in Maths.

We would also like to thank Mrs Kelly, who has stepped back from the role of Head of Science to return to being a teacher of Science. She has made an enormous contribution to the school during her time as Head of Department. We are delighted to have Mr Hunter and Mr Nash stepping into the role of Co-Heads of Science. This growing department have their sights set very high for the future.

Following the departure of Mr Rider (Teacher of Music) earlier this year, we have been very lucky to have Mr Ellis (from the Norfolk Music Advisory Service) and Mrs Espley taking care of the Music curriculum. However, we are looking forward to Mr Lott joining us in September and he has big plans to take Music to a whole new level. This also coincides with a project to relocate and renovate the music classroom to form a more integrated part of the PE and Expressive Arts team.



Principal's Letter

We are also saying goodbye to Mr Heron (Teacher of Art and D&T). Having progressed from technician, to apprentice teacher, to qualified teacher, he is now moving on to a promoted post at another school. We are excited to have appointed Mrs Holmes as teacher of Art and D&T and brings a wealth of experience from within the UK education system, as well as systems across the world.

We recently learned that Mr Jones (Supply Teacher/Cover Supervisor) has also chosen to retire. Mr Jones came to do a single day of cover/supply and 18 months later was still happy to keep coming back to the school when required throughout this time. We wish him all the best in his retirement.

Earlier this term, Mrs Barker (Finance Officer) made the difficult decision to retire following nearly 16 years in post. She has performed a great service to the school during turbulent financial times and we wish her all the best of health and happiness for the future. Following this, Miss Tuck (previously in Reception) assumed the role of Finance Officer and has shown what an asset she is in this new role.

I would also like to take this opportunity to thank Mrs Platten (Exams Officer) who plans to retire at the end of the summer break. She has given over 20 years of service to APHS, meaning that literally thousands of students have benefitted from her hard work and dedication.

Lastly, I would like to congratulate Mr Brett (Teacher of PE) who will be joining the leadership team for next year as Assistant Principal. We are very excited to see the impact he is going to make in this new role and help build the leadership capacity towards our ongoing mission to provide a world class environment for learning where all members of our school community can thrive.

On a personal note, I would like to thank all students, parents/carers, staff, the Wensum Trust, governors and members of the extended community for the support you have given me in my first year as Headteacher of this wonderful school. It has been an honour and a privilege, and I am extremely proud of the vast improvements we have made to so many areas of school performance and school life. I would like to particularly thank the Leadership Team of Mr Tawana, Mrs Hardman, Mrs Barker and Mrs Clarke for their exceptional hard work and commitment.

As we look forward to next year, the school will be celebrating its 60th anniversary and we will be doing so with the highest number of students on roll in the school's history. We are oversubscribed in every year group and remain the school of choice in the local area. Once we have all had a good break, we will get right back to our ambitious plans to ensure that APHS goes from strength to strength. As we recently celebrated at Holkham Hall: this is a [not-so] little school, with big dreams!

We look forward to welcoming back Years 7 and 11 on Wednesday 6th September and the rest of the school (Years 8, 9 and 10) on Thursday 7th September 2023. Enjoy reading this incredible newsletter and have a great summer.

Mr M Hardman

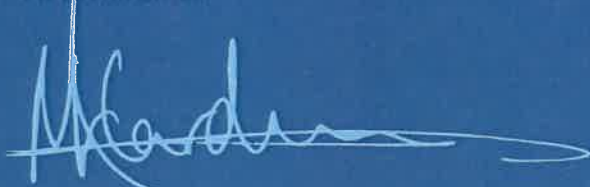

Principal



Year 10 Work Experience

During the Year 10 Work Experience Week we had 120 students who generated their own placements and carried out a variety of job roles across the different sectors of employment.

At Alderman Peel High School, we believe that Work Experience is an important part of the Year 10 Curriculum and is an excellent opportunity for young people to gain an insight into the 'World of Work' and to help prepare them for the responsibilities and opportunities of adult life. We believe that it improves understanding of how business and industry operate, improves self-confidence, self-reliance, and maturity, and helps students develop skills, which they will need throughout their life. We know it can be one of the most transformational experiences young people have during their education.

Here is what the students had to say...

"Work Experience helped me develop my communication skills with new people"

"I loved the Work Experience Journal to record what I had done and enjoyed every day, and filling in my self-reflection at the end. I found it really helpful and reassuring to have comments from my supervisor too"

"I enjoyed the chance it gave us to be independent"

Here is what the employers had to say...

"Just a quick email to say thank you for sending Daniel along to us at the Beach cafe. What a pleasure it has been to work alongside such a lovely, hardworking lad. Daniel came in with such a can do attitude, and has knuckled down. No job was too big and he became part of the team very quickly. I have been so impressed, that today I asked Daniel to come back and work some shifts at the cafe over the summer, starting after his birthday in a couple of weeks. So overall great success story."

"Oakley was a an exemplary placement and we will happily have him back again, anytime. He was a wonderful Ambassador for your school."

I was very impressed with the Aspiration and Tenacity our Year 10s demonstrated during Work Experience Week. We have no doubt that this experience has proved valuable and will prepare them for taking their next steps after year 11. I would like to extend our thanks to all employers involved, and congratulate our students for representing Alderman Peel High School so well. We have had lots of great feedback from employers, students and parents alike.

Well done!

Mr Bal Tawana



It's been a busy term in English with year 11s ramping up their revision, ready for their exams and year 10s having their eyes opened to not one but fifteen poems in the Power and Conflict anthology whilst also preparing for their second language mock due in the next couple of weeks. The English team have balanced out the heavy content of Key Stage 4 with encouraging the creativity in Key Stage 3 English.

Before May half term, year 8 studied Macbeth, and we were treated to some amazing homeworks of news articles about Lady Macbeth's Dastardly Doings alongside simply sensational scrolls of Lady Macbeth and Macbeth's diary entries (see photos.) The English team were blown away with the enthusiasm echoing in the upstairs corridors as lessons had pupils acting out the play - a truly wonderful way to welcome the Bard into their lives!

Year 9 haven't missed out on the creativity - some classes were able to choose a novel of their own choice to read in six weeks whilst others did a class novel together. Our end of term assessment of their understanding took a twist, as we asked them to produce 2D or 3D literal and figurative representations of characters, themes and plots in their novels. The concepts created were amazing! In classroom carousels, they shared their work, using words to share their ideas with all in the class. It really was a wonderful way to record their achievement on speaking and listening. This year group have now started on their GCSE Literature study, and are concluding the year on Romeo and Juliet.

Year 7s have wound their way around language and literature concepts over the year and are finishing with the whole year group studying the weird and wonderful ideas by Lewis Carroll in Alice in Wonderland. As well as working on their imagery being accurate in their creative writing (by using Back to Back drawing to show how IN accurate their ideas are!), we will end the year with them creating a deck of cards to describe the novella. We look forward to sharing what their deck of cards will look like at the end of this half term!

Mrs Murkin

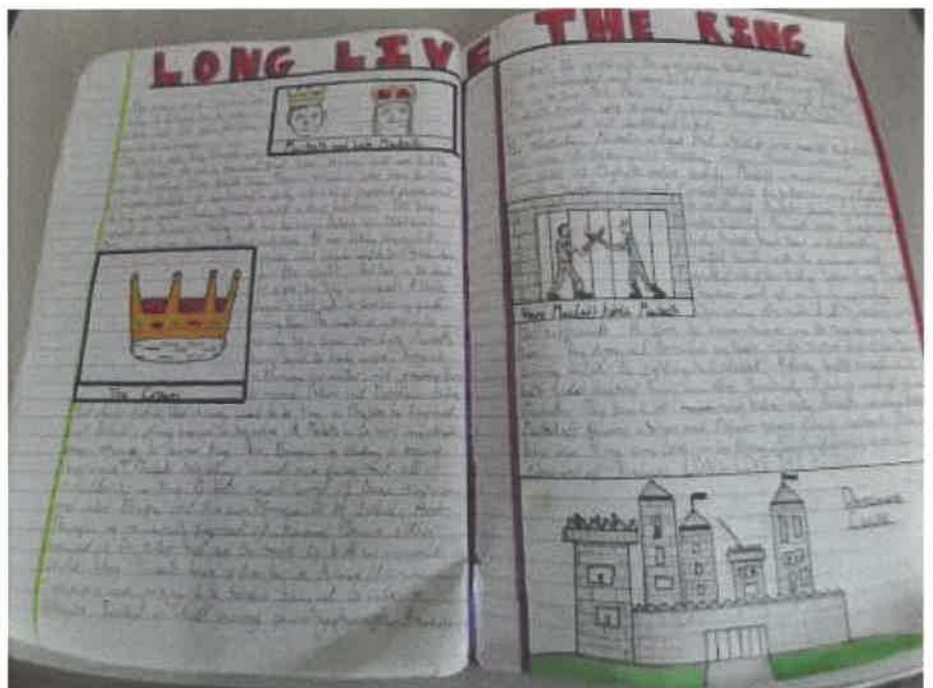
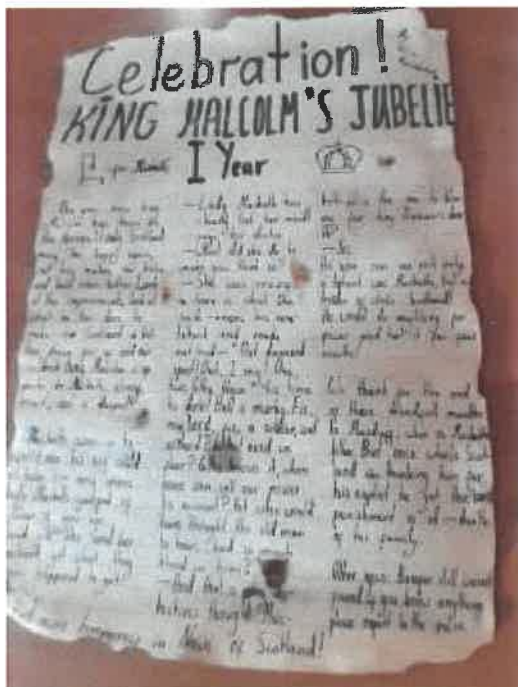

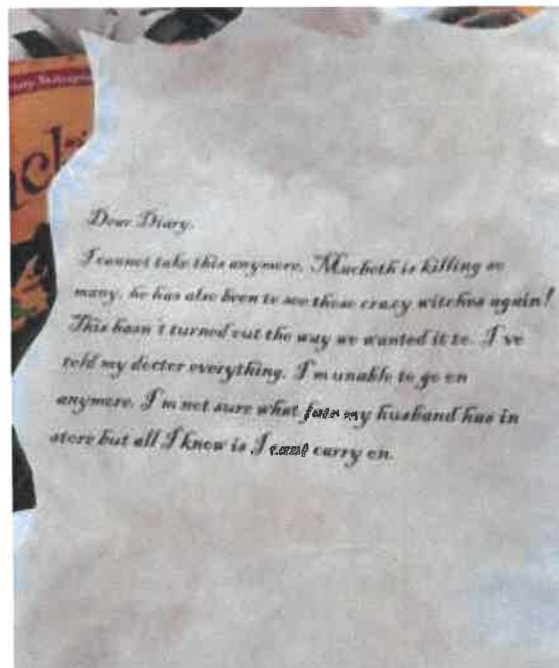
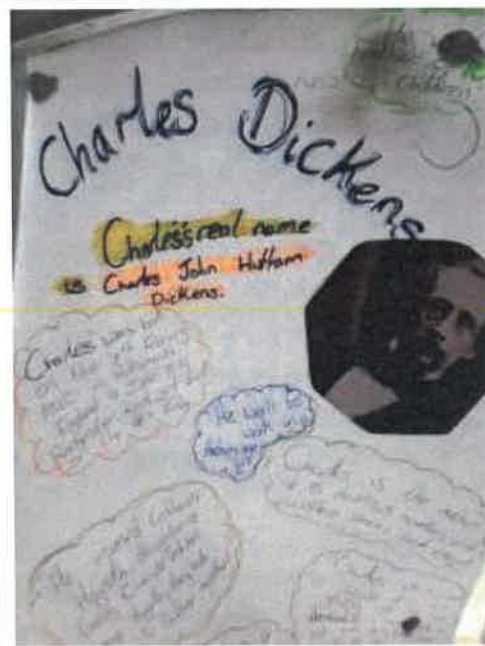
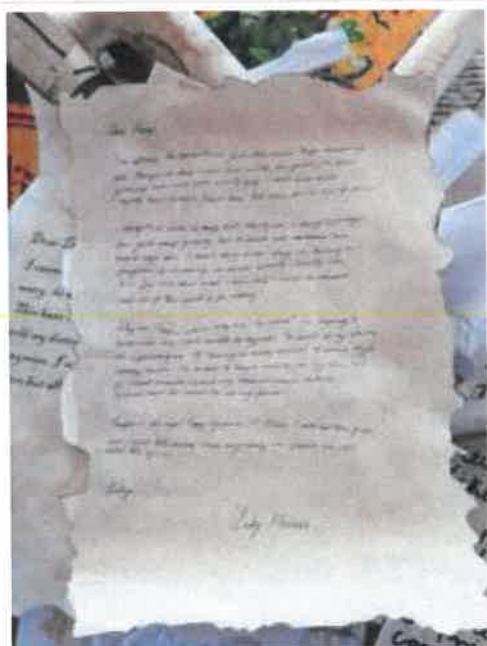
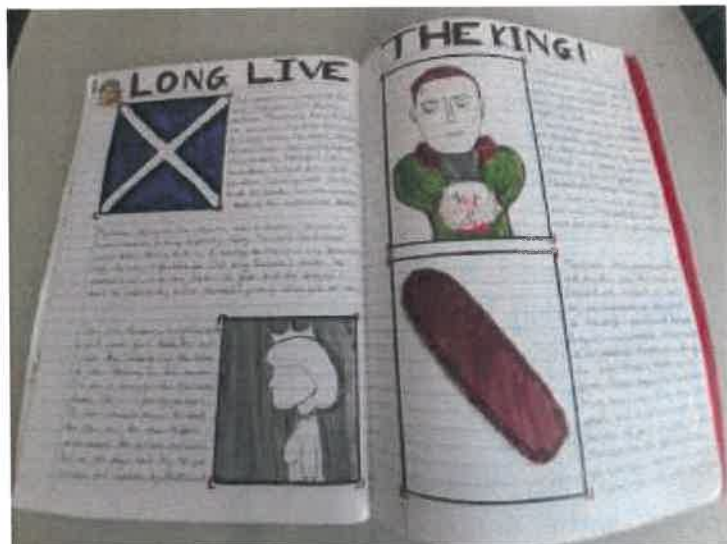

Taking Maths Outside the Classroom

Year 7 and Year 9 students enjoyed a memorable maths lesson outside in the 3G. Solving a series of connected problems, pairs and small groups of students had to complete the task as quickly as possible – with the promise of full-sugar treats as rewards for the winners! Mrs Long was our guest teacher for the lesson and the students thoroughly engaged with the work. It's funny how just taking things outside can spark enthusiasm!



The Science department at APHS has been busy with a range of exciting events and activities. Recently, students took part in the school's Science fair, showcasing their innovative ideas and projects to their peers and teachers. The fair was a great success, with the students demonstrating impressive creativity and scientific knowledge.

As a reward for their hard work, the Science department organized a trip for the students to the National Space centre, where they will have the opportunity to explore a range of scientific concepts and exhibits. This is a fantastic way for the students to further their understanding of science in a fun and interactive way.

The department also arranged for a group of students to attend The Norfolk Science and Technology challenge day at the Hewitt academy. This will be an exciting opportunity for the students to engage in a range of science-based challenges and activities, and to work collaboratively with other students from across the region.

Overall, the Science department at APHS is proud of the students' achievements and enthusiasm for science. The department is committed to providing engaging and inspiring learning opportunities, and looks forward to continuing to support students' interests and achievements in science.

Expressive Arts - Art

Breaking news!

Year 9 Fashionista, Zenepe Fox and her eco dress, aptly entitled "Breaking News" recently made an appearance at the APHS Holkham Awards 2023!

Zenepe and her team of enthusiastic year 9 fashion-assistants created a wonderful design, with newspaper shoes, that made it to the UK finals of the 'Junk Kouture, ' Microsoft sponsored, world Eco Fashion Competition . The busy and creative 14 year old girls got to the UK finals after beating first year University fashion students in the competition! They have since been tweaking their design, this time with the help of our resident APHS costume designer, Daisy Bolderstone.

The girls got together for a reception with popcorn and fizzy drinks to watch the "Junk Kouture "catwalk show, that was filmed live from London.

The girls thought that 'Breaking News' and her newsprint shoes looked stunning at Holkham Hall. Giving the dress the setting, she so deserved!



Term Dates - 2023 / 24

Open	(Students)	Wednesday 6th September 2023	Autumn Term
Close	(Students)	Friday 20th October 2023	
Half term holiday Monday 23rd October until Friday 27th October 2023			
Open	(Students)	Monday 30th October 2023	
Close	(Students)	Wednesday 20th December 2023	
Christmas holiday Thursday 21st December 2023 until Wednesday 3rd January 2024			
Open	(Students)	Thursday 4th January 2024	Spring Term
Close	(Students)	Friday 16th February 2024	
Half term holiday Monday 19th February until Friday 23rd February 2024			
Open	(Students)	Monday 26th February 2024	
Close	(Students)	Wednesday 27th March 2024	
Easter holiday Thursday 28th March until Friday 12th April 2024			
Open	(Students)	Monday 15th April 2024	Summer
Close	(Students)	Friday 24th May 2024	
Half term holiday Monday 27th May until Friday 31st May 2024			
Open	(Students)	Monday 3rd June 2024	
Close	(Students)	Friday 19th July 2024	

Expressive Arts - Art

Holt Festival Painting Workshop and Competition

A wonderful day was had by our Year 10 Artists learning, investigating and creating with the Holt Festival sponsored painting Workshop and artist in residence, held by the incredible Mary Blue Brady.

The theme was German Expressionism and Mary Blue engaged the students in discussions of art, history, psychology, colour mood and meaning.

The students watched a fantastic painting demonstration and then set to creating their very own stunning pieces, drawing and painting from a still life of fresh flowers, with bold colours and striking dark outlines. Drawing their inspiration from Mary Blue, to paint what they felt, as much as what they saw. Their work will be on display at St Andrews Church Hall, Holt as part of the Holt Festival, from 22nd -29th July where one of our APHS students will be awarded a prize.

Well done to all of our GCSE Y10s!



Expressive Arts - Drama

A final busy term for the Expressive Arts team with trips, performances, discos, competitions and workshops; there wasn't a quiet week in the whole of the summer term! We want to take this opportunity to thank all students who have taken part in everything that we have offered not only in school time but out of school, focusing on personal development and our school values.

Below is everything that took place this last term in just Drama alone:

KS4 MAGT and Y11 Drama students performed 'Extracts' at Wells Maltings in March. The evening of acting from modern and classic texts was performed by 29 students in front of two sets of audiences and was extremely successful in its reviews. There were extremely mature displays of acting in the chosen extracts including Prima Facie, 222: A Ghost Story, DNA and Top Girls. It is amazing the level of talent we have in KS4 and is of an extremely high standard; we are so proud of the level of commitment from these students. Well done!

Wells Maltings Theatre trip for Y9-11 to see Tapped produced by FiveOFresh was a hard-hitting tale of mental health and how allowing others to see your true colours could help rather than keeping it bottled up.

The first Y7 and Y8 'green effort badge' trip was to see the incredible Unexpected Twist with all Expressive Arts teachers at Norwich Theatre Royal attended by over 40 students. For lots of students this was their first time at the theatre or first drama they had seen live and it was a fantastic display of how beat boxing and singing could be integrated into Unexpected Twist as a re-telling of the Charles Dickens classic, Oliver Twist.

Y7-10 Drama trip to see the magical Charlie and the Chocolate Factory at Norwich Theatre Royal. We were very impressed how the stage completely transformed into Wonka's factory with CGI, LED and every colour of the rainbow you could imagine. It really was a world of pure imagination.

Y8&9 trip to see FADLOS' Little Shop of Horrors in Fakenham was an absolute delight, including Mrs Barker's husband as the eccentric dentist! A fantastic evening was had by all who attended.

Some of the Y9 students who are taking GCSE Drama got to see Blood Brothers in June as it came to Norwich on its current tour. Highlights were the character portrayals of Mrs. Johnstone and Mickey.

On the 30th June the Expressive Arts team put on the Rewards Disco for all Y7 & Y8 who achieved less than 5 behaviour points in Summer Term 1. It was a great success with many Y9 ambassadors (who also achieved less than 5 behaviour points for the whole year) supporting. It was a very fun evening for all involved.

Students taking part in Alice and Wonderland in King's Lynn Youth Players: George B, Maddy and Lily R, Tilly and Iris D.

Y10 Workshops took place with influences from Frantic Assembly and Paper Birds this term.

Y9 Arts Award. Students have been working on their Bronze award including sharing a skill with Y7 students in 'lessons' they planned and delivered in the last few weeks. It was wonderful to see how our Y9s took this task on with integrity and enthusiasm.

The display of photos you see on the next couple of pages are from the highlights above.

Expressive Arts - Drama



Expressive Arts - Drama



Looking forward

Matilda Jr @ APHS

By the time you have read this we would have cast this show coming to you in December! We look forward to rehearsals and hope you will join us for a fun filled evening in the Autumn Term

LAMDA @ APHS!

We are very proud to announce that as from September that LAMDA (London Academy of Music and Dramatic Art) are to start at APHS. LAMDA is one of the UK's oldest and most respected awarding bodies. LAMDA exams are about achievement - recognising and rewarding the endeavours of each individual. The ultimate aim is to provide all people with the opportunity to develop the life skills they need to be a success. It aims to teach and mentor students to the highest levels in the subject it covers, using a structured and creative approach to training and teaching in the following areas;

- Drama, building confidence,
- Movement, mime, poetry, speech.
- Television and film technique.

Similar to our existing Music Peripatetic lessons, we have a small group of students who will be working with our LAMDA teacher Carl Bradley and then students will be able to sign up to a waiting list for lessons. However! Thursday after school drama enrichment will be taken by Carl which will be open to students from Years 7-10 to take advantage of. More details about this will come out in the first week of September. We are looking forward to welcoming Mr. Bradley as part of our wider team on Thursdays.

Expressive Arts - Music

Music Performances/Events:

Piano Workshop - Wednesday
19th April 2023

- Music Performance - Bircham Windmill - Sunday 25th June 2023.
- Royal Norfolk Show - APHS Musicians - Wednesday 28th July 2023.
- APHS Music Recital - Thursday 6th July 2023
- Piano Students meet and perform for Mr Duncan Baker MP - Friday 7th July 2023. He was very impressed with the standard of our pianists.

Music Theory Club Badges

Well done to: Alexi E, Martha S, Matilda S, Bonita E, Kaitlin P, Adelaide C, Leo D, Ciara P, Isabella D, William S, Gabriella B, Olga B, Macie P, Jorja B, Alice J, Caleb E, Eliza W-B, Oliver B.

Music Theory is on FREE every Friday 3-4pm with Mr Preston in the canteen with refreshments available. All students work towards a grade.

Exams:

- Grace T (Year 9) - Grade 2 Piano - awaiting results
- Chloe Y (Year 9) - Grade 1 Violin - awaiting results
- Isabella D (Year 7) - Grade 3 Piano - awaiting results

Music Students of the Term

- Drums (Mr Lascelles) - Jake J
- Guitar (Mr Ashby and Mr Bush) - Henry C (Year 7)
- Woodwind (Mr Taylor) - Layla B (Year 8)
- Singing/Strings (Mrs Ballard) - Polina K (Year 8)
- Singing (Miss Cowell) Eloise O
- Piano (Mr Howell & Mr Preston) - Isabella D (Year 7) & Kyrulo N (Year 7)
- Music Theory Club - Adelaide C (Year 9)

Thank you APHS Musicians for all of your hard work during this Academic Year! From Miss Beech, Mr Howell, Mr Ellis and all the Peripatetic Team



History

Some of year 7 were set the challenge of creating a model of a castle as part of our Norman England scheme of work. The entries we had for the competition were once again fabulous with a spectacular array of mottes, baileys, keeps, palisades, battlements and portcullises. Students voted for their winners and prizes were handed out in lessons. A big thank you to all parents/guardians who supported the students in this project, the time and effort which goes into the creation of these models is astounding. Ones which were not taken home are now on display in our library.



Design & Technology

YEAR 6 TRANSITION SESSION

On Thursday 29th June, two groups of Year 6 students had fun in D&T learning about the advantages and disadvantages of robots and then they designed and made their own LED Robot Badge!



YEAR 7

This term, Year 7 students have been learning about timbers and how to use a range of hand and machine tools safely to make wooden 'Block Bots' using close tolerances by accurately measuring and marking out.

They were given the technical orthographic drawing as shown to work from and here are some of the students hard at work and three examples of their high quality outcomes made by Amelia S, Jake J and Karyss M.

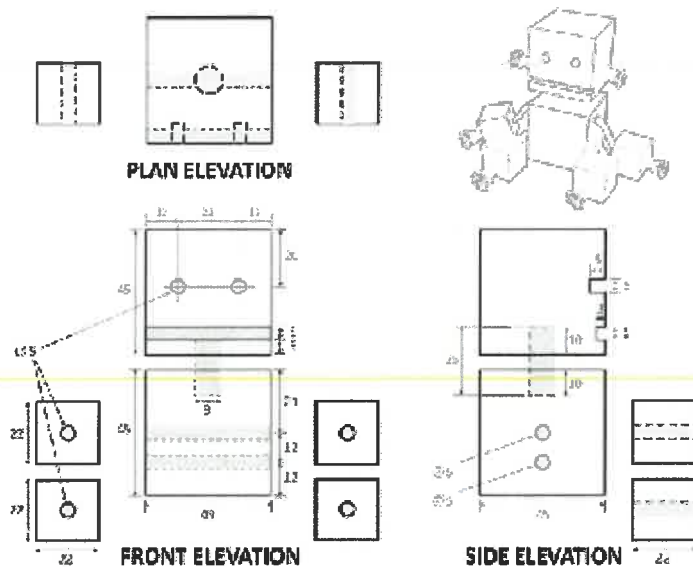

YEAR 7 - GIRL'S ROBOTICS DAY

On Monday 10th July, a class of thirty Year 7 girls, who have shown an enthusiasm for Design & Technology and STEM subjects (SCIENCE, TECHNOLOGY, ENGINEERING & MATHS), took part in a 'Sphero BOLT' Workshop Day. The workshop was run by Ross Hunter from Tablet Academy, which is an EdTech Training Provider created to support educational institutions in transforming teaching and learning by integrating new and existing technologies. The day included an introduction to programming, coding a Sphero BOLT and ended with a maze challenge!

This free workshop formed part of a prize won by Jorja B who came first in the 'Engenuity Skills Award' national design competition earlier in the year. In addition to the workshop and a cash prize of £75, Jorja was presented with her own Sphero Bolt thanks to Gill from Skills Awards! @engenuity.org



YEAR 8

This term, Year 8 students have been learning about mechanisms (levers, linkages, gears, pulleys and cams) and the 4 types of motion (linear, rotary, oscillating and reciprocating).

They were then challenged to apply their knowledge to design and make an automaton (moving toy) to create a moving scene about the effects of Climate Change (No.13 of the Sustainable Development Goals) and how they can directly impact on people and animals.

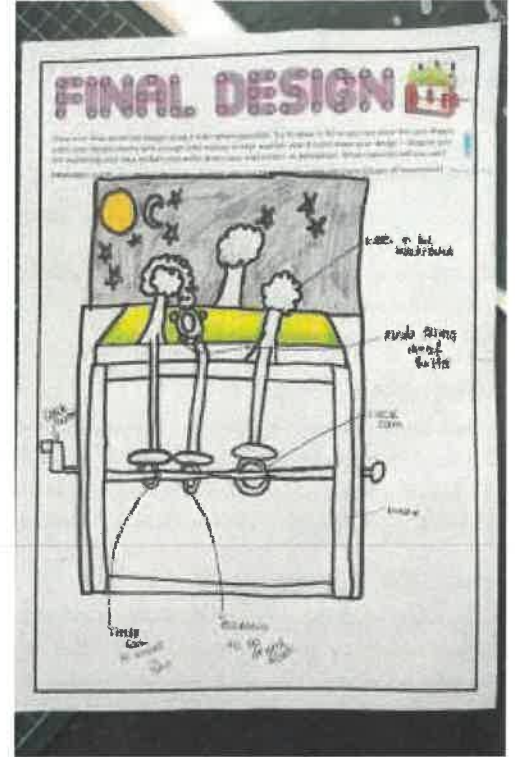
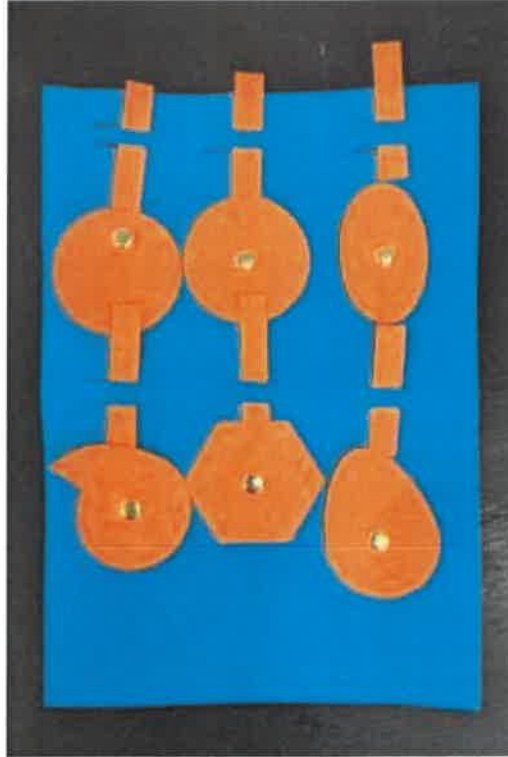

Design & Technology

Here are some excellent examples of their research homework investigating the effects of climate change and looking at the work of other automata designers to get ideas and inspiration for their own designs.

Archie W Y8 Research Homework: Climate Change & Automata design ideas

Climate Change Automata

This half term we have been tasked to create an automata that shows the effect of one part of climate change aimed at KS2 pupils. Here are different things on climate change and what it is doing to our planet.

What is climate change?

Climate change is the warming of our planet hence why it is also known as global warming. It is caused by air pollution by greenhouse gases being released. These gases add to our O-zone layer meaning sunlight and heat from the sun gets in to our atmosphere easy but struggle to leave meaning there is more and more heat building up inside the atmosphere.

How is it affecting our planet?

Climate change is affecting our planet in many different ways. It is causing hotter temperatures mainly which leads to many sub effects. It creates higher risks of forest fires which in England has caused massive forest fires starting from the start of the decade even though they hadn't happened for decades. It causes the ice caps to melt over time leading to rising sea levels. The rising sea levels and increased temp mean more storms and severe storms. The rising temperatures also mean it is harder to grow crops and that there is an increased amount of drought, for example, England's last drought in 2018 and 2021 were the first droughts in nearly 50 years. Higher sea levels lead to more flooding as well creating more poverty and displacement.

My Automata

I have chosen to do my automata on rising sea levels and flooding. The cams will make layers of water rise in front of land and ice caps. Here is an example of what I plan to base my design on.



Kenny M

Warming Ocean Currents

As greenhouse gases trap more energy from the sun, the oceans are absorbing more heat, resulting in an increase in sea surface temperatures and rising sea level.

Many oceans have increased about 1.5 degrees since 1901 and the temperature is still climbing, an average rate of 0.13 per decade.

If the ocean gets too warm it can lead to coral bleaching, accelerated melting of ice sheets etc.

Sea based automaton



Climate Change homework - Isaac H 8W

I plan to design my automata with some waves with rubbish in between it and make it move around and I might include a fish with rubbish around its neck to show what it does if you litter in the ocean.

Here is an example of a wave automata using eccentric cams that I have researched:

It could look something like this one below but I would like the waves to stand out more like the painting:



Daisy W Y8 Research Homework: Climate Change & Automata Designers

Rising Sea Levels

What can we do to act against this?

There are many different ways we can act against global warming, causing the large spike of polar ice caps collapsing into the arctic and Antarctic seas and oceans, using environmentally friendly products such as bamboo and paper instead of plastics and greenhouse gasses.

Statistics:

Sea Level Rise by Century



How does this affect our planet?

Rising sea levels are one of the most significant environmental challenges that our planet is facing today. The melting of polar ice caps, due to global warming, is causing sea levels to rise at an alarming rate. This rise in sea levels is threatening the livelihoods of millions of people living in coastal areas around the world. The increased frequency of floods, storms, and hurricanes due to rising sea levels is causing significant damage to infrastructure, property and human life. The loss of coastal wetlands, which serve as a natural barrier against storms and floods, is worsening the problem. Furthermore, the rise in sea levels is causing the salinization of freshwater resources, which is making it difficult for people to access clean drinking water. All these factors imply a severely large impact on the environment, economy and society as a whole.

Graph:

This graph shows a clear indicator as to which the rise in sea levels had varied from century to century. The first century shows a pretty stable sea level in contrast to the 20th Century which is a significantly higher bar in sea level rising.

Swiss designers, Pierre Jaquet-Droz, Henri-Louis and Jean Fredric Leschot:

These people were the first automata designers in the mid to late 18th Century/ 1700's. They were known for their very detailed automata designs, the Jaquet-Droz, made between 1768 and 1774.

The Jaquet Droz designs, we're specifically 3 dolls, The musician, The draughtsman, and the Writer. These dolls are still functional yet extremely delicate. Here is a photo of the dolls:



As you can see they are very detailed and delicate. The back of these designs are complex with many variations of motions, such as reciprocating and rotary. Here is an example of the back of these automata's:

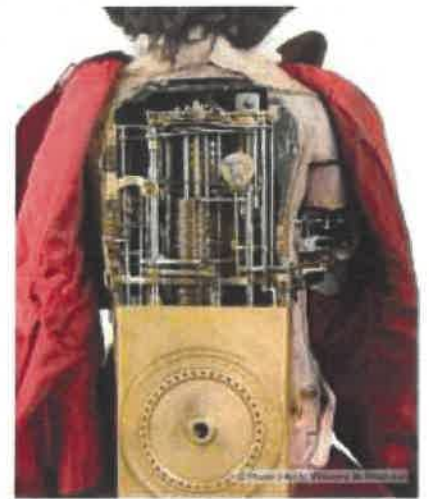

YEAR 9

Year 9 have been learning about sustainable design and the negative impact that our throw-away culture has on the environment and society. Their client for this unit is IKEA and their brief is to design a sustainable chair that is ergonomic, aesthetically pleasing and has the potential to be flat-packed.

As part of the design process, they were set homework to research IKEA's Circular Design Principles and the benefits of a circular economy.

They were given freedom on how to present their independent investigations and I was particularly impressed with the excellent examples shown here by Holly H, Isabelle W, Will S, Tilly F, Oliver H, Mallory G, Ollie B and Trinity H!



Design & Technology

IKEA Sustainable Seating

Designed by [Name]

This is a report on the sustainable office chairs that have been designed for the [Company Name]. The report discusses the design process, the materials used, and the environmental impact of the chairs.

What is a circular product?

A circular product is one that is designed to be used, repaired, and recycled. It is a product that is designed to be part of a circular economy, where resources are used efficiently and waste is minimized.

IKEA Seating Chair

IKEA

Designed by [Name]

This report discusses the design of sustainable office chairs for IKEA. It covers the design process, the materials used, and the environmental impact of the chairs.

IKEA Circular Principles

Design for STANDARIZATION: To make it easier to produce and assemble.

Design for FUNCTION: To make it easy to use and adjust.

Design for ADAPTABILITY: To make it easy to change and upgrade.

Design for REPAIR & MAINTENANCE: To make it easy to fix and maintain.

Design for QUALITY: To make it durable and long-lasting.

Design for PRICE: To make it affordable.

Design for SUSTAINABILITY: To make it environmentally friendly.

Design for RECYCLABILITY: To make it easy to recycle.

SUSTAINABLE SEATING

IKEA, by 2030 are trying to regenerate resources while growing their business. They aim to only use responsibly sourced, renewable or recycled materials in their offer and have a positive impact by regenerating resources, protecting ecosystems and improving biodiversity.

The 6Rs are essential to IKEA's and many other brands. They stand for: Reduce, Re-use, Repair, Recycle, Refuse, and Re-think. These help to cut down the amount of wastage caused in manufacturing items, such as chairs.

For 20 years, WWF and IKEA have been working side by side on peat, carbon, water and climate. Through their efforts to protect landscapes, enhance biodiversity, and empower local communities, they aim to inspire other organizations to do the same for a Planet Future.

IKEA's Circular Design Principles Drive Sustainability

IKEA, the Swedish furniture retailer, is increasingly emphasizing sustainability with its circular design. By adopting an eco-conscious approach to product development, IKEA aims to reduce waste, conserve resources, and build a greener future for the environment and its customers.

Circular design is at the heart of IKEA's sustainability strategy. This means designing products with longevity, ease of repair, and the ability to be recycled. By embracing circular design principles, IKEA has established a business model aligned with the circular economy, reducing waste and increasing resource efficiency.

A cornerstone of IKEA's sustainability efforts is the establishment of material parks for the future. This initiative involves creating dedicated production sites for re-use and recycling of materials used in their products. By having their own dedicated sites for materials after their useful life, IKEA minimizes waste back into the manufacturing process. This reduces the demand for raw materials, minimizes waste, and supports the concept of a circular economy.

The concept of material parks involves a closed-loop system, where materials circulate within IKEA's ecosystem. By doing so, the company reduces its carbon footprint, lessening the environmental impact associated with extraction and production. Moreover, it gives IKEA better control over material quality and availability, decreasing dependence on external suppliers.

Material parks enable IKEA to take a proactive approach to waste management. The company focuses on recycling processes that can be easily implemented, allowing materials to be re-used or recycled. This approach promotes longevity, reparability, and eventually, reusing materials to extend the life of their furniture for the next cycle for its customers.

Through circular design principles, IKEA has significantly improved its sustainability performance. By rethinking supply chains and manufacturing processes, the company has reduced its carbon footprint, minimized waste, and increased resource efficiency. Initiatives like "Design Life for Furniture" and "Buy Back and Reuse" encourage customers to spend smart, helping to prolong the life of their furniture and reduce waste, forming a culture of reuse and contributing to a more circular economy.

IKEA's circular design initiatives have also resonated with customers, aligning with their values and increasing demand for sustainable alternatives. The company's commitment to circularity has made its products more appealing to environmentally conscious consumers, giving IKEA a competitive edge in the market.

As a customer, IKEA's circular design principles promote longevity and profitability, ensuring sustainability. Through material parks, the future and better tomorrow, IKEA is paving the way for a greener future, where waste is minimized, resources are conserved, and a circular economy is achieved.

How do these products help the planet?

The circular economy is a system that is designed to be used, repaired, and recycled. It is a product that is designed to be part of a circular economy, where resources are used efficiently and waste is minimized.

Design for STANDARIZATION: To make it easier to produce and assemble.

Design for FUNCTION: To make it easy to use and adjust.

Design for ADAPTABILITY: To make it easy to change and upgrade.

Design for REPAIR & MAINTENANCE: To make it easy to fix and maintain.

Design for QUALITY: To make it durable and long-lasting.

Design for PRICE: To make it affordable.

Design for SUSTAINABILITY: To make it environmentally friendly.

Design for RECYCLABILITY: To make it easy to recycle.

How do these products help the planet?

The circular economy is a system that is designed to be used, repaired, and recycled. It is a product that is designed to be part of a circular economy, where resources are used efficiently and waste is minimized.

Design for STANDARIZATION: To make it easier to produce and assemble.

Design for FUNCTION: To make it easy to use and adjust.

Design for ADAPTABILITY: To make it easy to change and upgrade.

Design for REPAIR & MAINTENANCE: To make it easy to fix and maintain.

Design for QUALITY: To make it durable and long-lasting.

Design for PRICE: To make it affordable.

Design for SUSTAINABILITY: To make it environmentally friendly.

Design for RECYCLABILITY: To make it easy to recycle.

TASK 5

Connect with the design and technology. Create a list of different objects.

Standards
 Competence
 Creativity
 Innovation
 Problem Solving
 Teamwork
 Communication
 Critical Thinking
 Self-Management
 Social Responsibility

Objectives
 To identify and describe the objects and their uses.
 To classify the objects into different categories.
 To describe the objects and their uses.

TASK 6

Document the mechanical systems of a bicycle.

<p>Task 1: Introduction</p> <p>Most products are made up of many parts. Some of these parts are called components. Some of these components are called sub-assemblies. Some of these sub-assemblies are called systems.</p>	<p>Task 2: Components</p> <p>Each use mechanical advantage to make things work. Applying pressure can make things move. This is the type of force we use when we push or pull. This is the type of force we use when we lift or lower. This is the type of force we use when we twist or turn.</p>	<p>Task 3: Systems</p> <p>Every machine has many different parts. Each part has a different job to do. The parts of a machine are called components. The components of a machine are called systems. The systems of a machine are called sub-assemblies.</p>
<p>Task 4: Components</p> <p>A car has many parts. Some of these parts are called components. Some of these components are called sub-assemblies. Some of these sub-assemblies are called systems.</p>	<p>Task 5: Systems</p> <p>Each use mechanical advantage to make things work. Applying pressure can make things move. This is the type of force we use when we push or pull. This is the type of force we use when we lift or lower. This is the type of force we use when we twist or turn.</p>	<p>Task 6: Sub-assemblies</p> <p>Each use mechanical advantage to make things work. Applying pressure can make things move. This is the type of force we use when we push or pull. This is the type of force we use when we lift or lower. This is the type of force we use when we twist or turn.</p>

TASK 7

Design a chair for a specific purpose.

Standards
 Competence
 Creativity
 Innovation
 Problem Solving
 Teamwork
 Communication
 Critical Thinking
 Self-Management
 Social Responsibility

Objectives
 To identify the purpose of the chair.
 To design a chair for a specific purpose.
 To describe the chair and its parts.

TASK 8

Document the mechanical systems of a bicycle.

Standards
 Competence
 Creativity
 Innovation
 Problem Solving
 Teamwork
 Communication
 Critical Thinking
 Self-Management
 Social Responsibility

Objectives
 To identify the mechanical systems of a bicycle.
 To describe the mechanical systems of a bicycle.
 To explain how the mechanical systems of a bicycle work.

Y9 Homework: Hully H

Front Cover

Inside

What are IKEA's customer products main principles?

How is the product process designed? Review the product design process. The product design process is a series of steps that lead to the final product. The product design process is a series of steps that lead to the final product. The product design process is a series of steps that lead to the final product.

How do we create a product?

The product design process is a series of steps that lead to the final product. The product design process is a series of steps that lead to the final product. The product design process is a series of steps that lead to the final product.

What do they mean by creating 'modular bags for the future'?

Products today are not modular. They are not designed for the future. They are not designed for the future. They are not designed for the future. They are not designed for the future.

Reuse

Once people acquire a product, the product enters the first product life cycle. Reuse is how we describe the customer use of the product and it includes all aspects of normal products use and care, such as maintaining its condition and adapting them to the changing needs of life.

Ikea circular design

by Mallory G

The design principles

#1. Designing for renewable or recycled materials

Circularly means choosing the right materials from the beginning

Choosing renewable and recycled materials is fundamental to sustainable design, production, consumption, and business. This is one way to ensure products withstand the test of time.

This principle is relevant for all our material choices.



#3. Designing for care

Circularly means creating the life of products through maintenance and protection.

When developing products, it is essential to think about how the products will be used in everyday life. Are there parts that are easily worn and replaced? Can they be redesigned to last longer? What maintenance requirements will people have to care for long the product. In our long "change" life, ensuring products like tools, garden stoves and saws, power tools, and outdoor furniture can last for many years is important. We also think about how to design products that are easy to maintain and repair. In addition, we think about how to design products that are easy to repair and maintain.



#5. Designing for adaptability

Circularly means designing products that can help creating common needs.

In a world that is always changing, it is essential to think about how the products will be used in everyday life. Are there parts that are easily worn and replaced? Can they be redesigned to last longer? What maintenance requirements will people have to care for long the product. In our long "change" life, ensuring products like tools, garden stoves and saws, power tools, and outdoor furniture can last for many years is important. We also think about how to design products that are easy to maintain and repair. In addition, we think about how to design products that are easy to repair and maintain.



#7. Designing for remanufacturing

Circularly means using existing materials and parts in the production of new products.

In a world of finite resources, our products play an important role in recovering resources for the future. Through remanufacturing, we can reuse materials from old products for new ones. For the sake of efficiency, it's vital to understand the process of remanufacturing and have a close relationship with the manufacturing partners and product engineers. It's vital to the development of new products and understanding our own processes, choices, and energy. This is also a great way to contribute to a better product price.



Circular Design

What is a circular product? For IKEA, it's a product with built-in design features and capabilities for environment reuse, refurbishment, remanufacturing, and at the very end of life, recycling. Not all products have the same possibility to be circular, and therefore, there is no one single recipe for circular product design. Instead, it is a combination of various circular product design principles that together create a built-in possibility for all products to last as long as possible, and eventually be given a second life for new products. At IKEA, we have described these principles to better understand how we can enable products to be circular.

#2. Designing for standardization

Circularly means creating products that are easy to repair, reuse, refurbish, remanufacture, and eventually recycle at the end of their life.

Standardization creates possibilities for products to move through the stages of reuse, refurbishment, and remanufacturing at a faster and more efficient rate, reducing waste at the end of their life. By using standardized things, the number of unique parts needed to produce something is reduced, the amount of waste is reduced, and the number of different parts needed to produce something is reduced.

There are five main ways to create standardization in our products:

1. Use of standard components, fittings, and parts.
2. Use of standardized materials and manufacturing techniques.
3. Use of standardized components to create interchangeable parts with other products.



#4. Designing for repair

Circularly means designing products that are easy to repair, reuse, refurbish, remanufacture, and eventually recycle at the end of their life.

Standardization creates possibilities for products to move through the stages of reuse, refurbishment, and remanufacturing at a faster and more efficient rate, reducing waste at the end of their life. By using standardized things, the number of unique parts needed to produce something is reduced, the amount of waste is reduced, and the number of different parts needed to produce something is reduced.



#6. Designing for disassembly and reassembly

Circularly means using reuse, refurbishment, and remanufacturing, and eventually recycling at the end of their life.

When designing products for reuse, they must be easy to disassemble and reassemble, allowing the use of materials often ending their useful life. This allows for reuse, refurbishment, and remanufacturing. This allows for reuse, refurbishment, and remanufacturing. This allows for reuse, refurbishment, and remanufacturing.



#8. Designing for recyclability

Circularly means choosing materials and how they are separated to enable recycling.

Products today are our material legacy for the future. They can be recycled or reused. Products designed for recyclability are using recyclable materials and can be easily separated based on knowledge about the industrial recycling processes.



Design & Technology / STEM



They are currently experimenting with modelling chairs using different materials as part of the iterative design process, with some very creative results, particularly from Harry H, Milo M and Archie R!



Local Design Competition Winner

Well done to Izzy R in Year 9 for creating the winning design for Burnham Market Nursery School's 50th Anniversary logo which they chose from over a hundred entries!

They loved Izzy's design because it incorporated their existing logo along with flowers which reflected their new outdoor learning area. Izzy received a £20 Amazon voucher from Elisa Bray, Manager at Burnham Market Nursery, and her logo design will feature on all marketing during their 50th Anniversary year!



Trip to Sizewell B Power Station

On Wednesday 5th July, 30 students enjoyed a trip to Sizewell B Power Station to learn first-hand about nuclear energy generation which is a topic that forms part of the Design & Technology, Science and Geography GCSE curriculums. This 'STEM in Action' trip included a tour of the nuclear site, a careers talk providing an insight into potential jobs within the energy sector, an opportunity to hug a turbine and a free ice cream! Big thanks to Vicky and the EDF Energy team at the Sizewell B Visitor Centre!



Design & Technology / STEM

KS4 - Year 10

For the first half of the summer term, Year 10 have learned about metal, textile and polymer material properties and processes. This included carrying out conductivity tests on a range of materials, experimenting with pewter casting, bending aluminium wire to make sea glass jewellery, using lino cutting techniques to create block printed Coronation bunting, heat bending acrylic and applying vinyl cut lettering to make fun 'poly-glasses'!

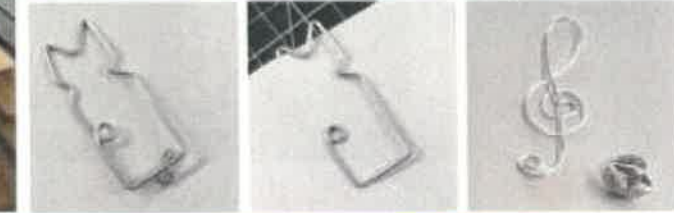

Design & Technology / STEM



Design & Technology / STEM

For the remainder of the term, the students have been challenged to apply all the knowledge and skills they have gained over the past academic year to create an 'Eco-Bio-Lamp'. This unit is designed as an introduction to their NEA coursework project which will start in September. The context is 'Lighting up your home' and their brief is to design and make an adjustable lamp inspired by nature ('biomimicry') using any of the materials and processes they have learned about (papers & boards, timbers, metals, polymers and textiles). Last year we had some amazing outcomes so I look forward to seeing what this cohort create!

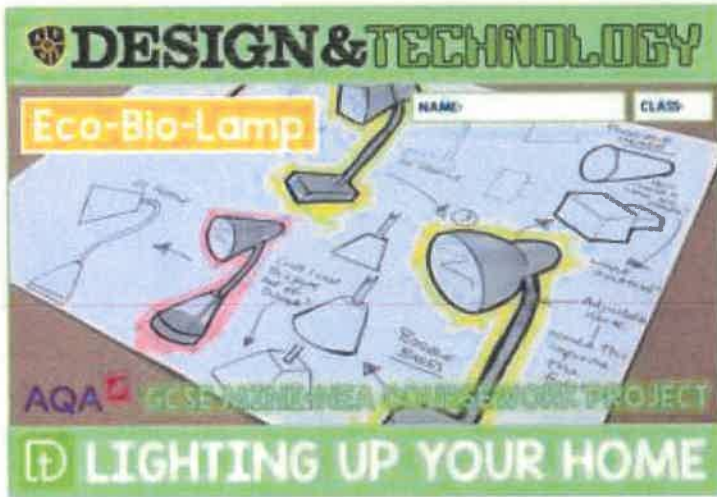

Trip to NUA 'Gradfest23' Degree Show

On Friday 16th June, Year 10 enjoyed an inspiring trip to Norwich University of the Arts (NUA) Degree Show, which included outstanding work by students studying Animation, AVFX, Interior Design, Architecture, Graphics and illustration. We look forward to welcoming Sen Thompson from NUA who is coming to APHS to run an animation workshop for Year 9 & 10 students interested in game design on 18th July.



Design & Technology / STEM

Student Feedback following the trip to NUA Gradfest:

"We learnt about all the courses we could do in the future. We were inspired by the architecture and interior design, our favourite thing about the exhibition was the photography and graphic design. Our favourite artwork was the picture of Sydney Corbin." - Bethany

"I thought it was very interesting, especially the interior design sections, which had models of houses and design plans." - Oliver H

"I thought it was very inspiring finding out about all the job opportunities." - Harry C

"I thought it was an excellent experience finding out about what I could do after Sixth form. Definitely would recommend to anyone wanting a career in the creative industry." - Will S

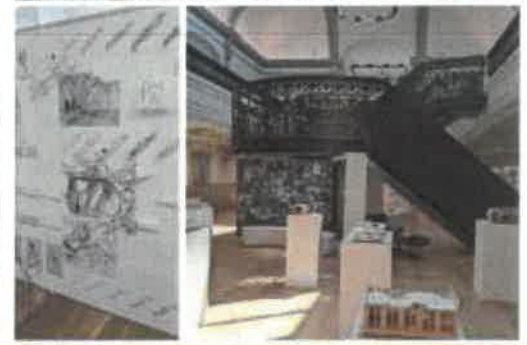

Year 10 Work Experience

Well done to Joel C who completed his work experience week at 'Flights of Fantasy, Creative Play' in Dersingham.

Joel not only learned about designing and making bespoke children's play equipment and how to use Sketchup to create realistic virtual 3D models, but he gained them as a client for his GCSE coursework project next year to design a product on the theme of 'playing games'!



Greenpower F24 Electric Kit Car Club

On Sunday 25th June, our team had an amazing day out at Lotus Test Track in Hethel, Norwich, racing our kit car against other school teams in the Greenpower Regional Event. We ended the day coming 21st out of 38 which was a fantastic achievement for our first foray into the world of motor racing! We also won the award for best 'Portfolio' which we created to document our amazing journey over the past year!

Well done to all of our Greenpower team and thank you to all our sponsors and to everyone who has supported our club, especially Mr D Frowhawk (ICT Technician) and Mr T Sutton (Site Manager) who have worked alongside the students all year and congratulations to Sam Pickard (Year 10), our team leader, who gained a week's work placement at Lotus Cars!

Our Greenpower Team would like to say a special thank you to SCILLITOE BROS!

Without the generous help of Kieron Scillitoe and his team @ScillitoeBros our F24 electric kit car would not have made the Greenpower Regional Event at Lotus! We had an issue with our rear axle in May, which they not only came to our rescue and helped fix, but ended up providing ongoing expert help and advice on how best to proceed and mentored our team right up to the big day to get our car race ready!

Kieron and Gavin even gave up their Sunday to come and support us at the event on 25th June and have attended our afterschool club each week since to discuss plans for next year! The exciting news is we have ordered a second kit car thanks to an additional grant from Norfolk Community Fund and Kieron and Gavin are keen to continue supporting our club next year! They are already looking at ways they can help us to make our existing car more aerodynamic to improve our time and have plans for making our second kit car even better!

Thanks to the inspiring professionals @ScillitoeBros our students have also gained an insight into the world of race mechanics and future career opportunities in engineering!



STEM





Y7 Big Bang in school STEM day

On Tuesday 11th July, all of Year 7 will be taking part in a number of workshops including a boat design workshop thanks to Neil Thompson Boats, a VEX Robotics workshop thanks to James Clarke at Hethersett Academy and 2 workshops thanks to Energy Quest where students will learn how to use fruit to power mobile phones!



Trip To RAF Honington – Robotics Competition

The lunchtime Computer Science club entered the EEP Robotics challenge at RAF Honington in Suffolk. RAF Honington is home to the RAF regiment, they hosted the challenge and provided an insight to our pupils on the role of the RAF regiment and the importance of STEM subjects. At the time of our visit the regiment was preparing for humanitarian aid flights and the evacuation of civilians from the conflict in Sudan. They were excellent hosts and made the day very memorable to all our students

The competition was broken up into many tasks and our students had a go at all the tasks, some with more success than others, we came second in the presentation task and got a certificate for best teamwork at the end of the day.

One of our team Millie wrote this short report:

When our school visited Honington it was for a robotics challenge. We went to Honington just as a learning experience as most of us were all new to robotics.

We did the speed competition, even though we weren't the fastest out of the schools, we learnt new ways to improve our robot so that it would go faster.

Our team also competed in the mat competitions. We had spent the previous months designing, coding and building robots to complete a series of tasks on the mat. Even though our robots maybe didn't always work as well as we hoped, we still learnt how we could improve for future competitions.

Overall our visit to Honington was a great learning experience for all of us. The staff team at Honington were very friendly and informative, helping us realize what we would need to do to improve our robots.

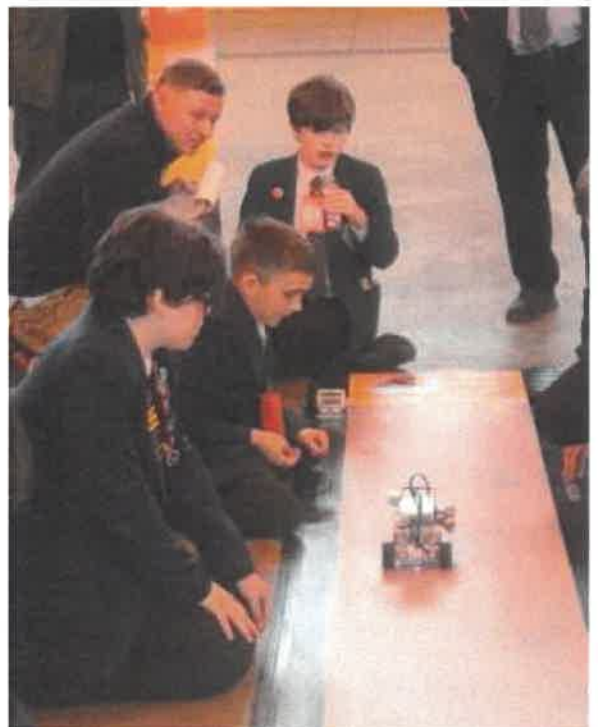

E-Safety

TOXIC INFLUENCERS

An article by our Pupil E-safety Ambassadors (with a little help from Mr Corby)

Social media can be a really valuable and useful tool for us and our children. It allows friends to keep in touch, children to socialise when they live in isolated communities. It allows parents to keep in touch with their children when they are away from the family home. You can find out information, learn new skills, keep yourself entertained and so much more. There are plenty of positives to social media it can be empowering and a positive experience but also a dark side that children and parents need to be aware of when using social media. In this article we are going to look at toxic influencers.

Toxic influencers are simply people who use social media to give bad and sometimes even dangerous advice.

Social media platforms rely on algorithms to produce recommendations and feeds. **So, once you seen one bit of bad advice, your social media site will find you more feeds with similar viewpoints.**

Toxic influencers, may promote radical viewpoints, beauty advice that may affect your children's ideas on their body image, opinions on racism and misogyny (that are unacceptable). Children often find such sites as their friends use them and peer pressure can build up to watch these sites and share the same opinions. It becomes a vicious circle.

What is misogyny?- it's a contempt or even hatred of women, it is basically saying men are superior to women and a woman's role is to serve men.

Recently in the news there has a lot of news about Andrew Tate, he is a toxic influencer as he has views about women that are misogynic and uses his wealth and his fame as a fighter to reinforce them.

Less obvious toxic influencers may give health and beauty advice, this can have a major impact on self-worth, esteem and mental health. Such influencers may encourage an obsession with fitness, losing weight, getting that perfect appearance and they often lead to low self-esteem and poor mental health and quite often give seriously bad if not dangerous advice.

Want to know more? The following short film by the beauty company Dove will make you think about toxic health and beauty influencers.

On YouTube in the search bar type "Toxic Influence: A Dove Film | Dove Self-Esteem Project"

Or use the following link <https://www.youtube.com/watch?v=sF3iRZtkyAQ>

So what should you do to tackle toxic influencers?

As a family you can:

1.Talk about the online sites and influencers you follow. Discuss their viewpoints make this part of your regular routine.

2.Discuss as a family what influence your friends have on what sites you visit and consider how this might affect your opinion. **Peer pressure is real and it is important that you can recognize it.** (A good example is Prime drinks, how many of you have wanted to get hold of a bottle because, the internet, and your friends wanted it, did it make you or someone you know want to buy it?)

3.Set boundaries on what sites/influencers you should and should not follow.

4.Sometimes social media influencers, can change your values and opinions. If parents or teachers challenge your opinions, listen to them with an open mind and discuss the concerns they have.

And remember if you need to talk you can always speak to any member of the SPRO and child safeguarding team at APHS.

We are off to Estonia for the World Championships!

The robotics club learnt from their experience at RAF Honington and on their arrival back into school started preparing new robots for a competition to be held at Sheringham School, where there were two robotic competitions to enter. There was a competition for Lego Sumo robots and Lego Line followers. The club was really motivated after their experience at Honington and we soon had over 10 teams creating robots for the event.

The robots took a lot of dedication to complete and many lunchtimes were spent refining the robots and the code they used.

We arrived at Sheringham on the 3rd of July for the competition. We entered 3 teams for the Lego Sumo and an impressive 7 teams for the line following event. We had practiced for this competition at school and knew our robots worked.

In the sumo competition our robots started well, all won at least one bout and progressed to the next stage. It was a hard fought competition and we reached the semi finals before being knocked out. Considering many of the opposition teams had been developing their robots for over a year we felt this was a really good result.

Now the excitement was really building up. We knew we had several very competitive teams in the Line following team, but also that the course was very challenging and difficult to complete. In practice Iryna and Polina with the robots Cucumber & Tomato, Millie with the robot Twilight Sparkle, Jack and Harvey Robot Team Dave all looked very competitive but had not quite finished the course. Leyla and Cloe (Cloe could not make the competition so Leyla was on her own) in Team Luna and Kit with the robot TBD had completed the course, but until the competition started we did not know how good our opposition was.

The competition started with Leyla and the robot Luna, everyone was amazed at the speed it went around the course and it completed the circuit in 45 seconds. The first of our competitors then went and they only made it part of the way around the course. Then another that completed the course in 1min 6 seconds. By the end of the first round Leyla with team Luna was in first place and Kit with TBD was in third.

In the second round only Leyla with Team Luna completed the course, her time was fractionally slower. Millie with Twilight Sparkle showed a lot of potential her robot getting as far as the final crossroads at an astonishing 34 seconds but unfortunately did not complete the last corner.

We then entered the final round with only four teams completing what was a very tricky course. Both Kit with team TBD and Leyla with Luna completed the course, but no improvement in times. We were then left to watch all the other teams compete but none of them got even close to team Lunas time. At the end of the competition Leyla and the robot Luna had won the competition 10 seconds faster than anyone else.

After the competition we had a short talk about careers in engineering/stem industries and then the prize giving. Leyla and Cloe, had won! The prize was to go on to compete in the World Championship in Estonia this November. We wish them the best of luck and would also like to thank the sponsors of the event Equinor/Dudgeon (The wind farm company) for funding the trip and this event.





We all have something to hide

Important E-safety information for parents – Hiding Apps

We all have something to hide, is a well-used cliché. Most of our children have smartphones and when they use them we want to make sure that they are kept safe and shielded from online dangers.

There are many apps that can hide their activity on the internet, may be conversations, photos, videos or even social media apps. The following link will tell you much more about this and what to look for to deal with this problem and help to ensure your child stays safe online. <https://www.security.org/news/teen-hiding-apps/>

Excelsior Sailing Trip

We were delighted to be able to offer 3 fully funded sailing residentials this year to our students. This was due to the generosity of **The Langley Foundation**. The Langleys are a sailing family who live in Blakeney, they have their own professional racing team in the TP52 class, **The Norfolk Boat, Neil Thompson Boats and Excelsior**. The first trip was 5 nights sailing on the Excelsior around the UK, involving ten Year 8 & 9 students. The second trip was 5 nights sailing on the Excelsior and visiting countries such as Belgium, involving ten Year 8 & 9 students. The final trip was a Year 11 celebration trip, 10 nights on board the Excelsior and these students took part in the prestigious Tall Ships Race from Den Helder, Netherlands to Hartlepool and even won the **Best in crew parade award!**

Testimonials from the students in Year 8 & 9.

We had the best time ever. I loved to try all the experiences, I am so grateful that I had the honour to learn how to sail and go to Brugge. My shifts may have been early 12pm to 4am but I am forever grateful for this whole trip, thank you! PS. I will learn how to walk on a pontoon! Ava H Y8

We had the best trip to Brugge with fantastic weather and great food, I learnt how to haul up sails and tie knots. As my shift was at 4am I saw the most beautiful sunrises. I would like to thank Harry and Jazz for being my watch leaders I had a great time and also so happy to have met such amazing people who I would not usually talk to at school. Thank you for giving me this opportunity to participate in an amazing trip I will never forget. Julia C Y8

My experience with excelsior is something I cannot fully describe. The opportunity sounded almost unreal. I connected with people I never even imagined clicking with, and got to know my teachers who have taught me for 3 years! It gave me the chance to push myself in multiple ways and to discipline myself with the help of the crew. Our days and adventures in Brugge and at sea are times I will never forget and for that I am grateful. Purity O Y9

To excelsior thank you so much for this amazing opportunity and how much I have learned about sailing and also myself. Before this I had never left the UK and now I know Belgium is 'too hot' I will also never forget Marnie's laugh! Thank you so much. Harry H Y9

The excelsior trip was absolutely incredible! It was an amazing experience and I learned so much about sailing a 102 year old boat! Thank you so much for this brilliant experience APhS! I have learned various knots such as the round turn two half hitch, the cow hitch and countless others! Had a good time in Brugge, loved the waffles! I also learned how to hoist the sails and steer the ship. Thank you to Charlotte and Marni my watch leaders. Alex P Y8

Our trip on the excelsior was one of a kind, I could never imagine that I would sail across the North Sea to Belgium. Although I did get sea sick the trip was amazing. Massive thanks to Olley my watch leader, Mr Heron and Miss Golding for accompanying us and the rest of the sailing crew. Freddie B Y8

My experience with excelsior was phenomenal, we had a wonderful few days in Belgium. The crew were all lovely and my favourite was Marnie who had an excellent laugh, sounded just like a seal. The rope race was a fun addition, my group Sparrow won by a lot of points! I think it was the best school trip ever and I will remember it forever! Tilly F Y9

The excelsior trip was an amazing experience. I loved every minute of it, the experience of putting up the sails and running the ship was unreal. I got a chance to speak to people I never thought I would ever speak to. I am very thankful to the crew for the opportunity to sail to Belgium. Thank you! Kieran D Y9

The excelsior trip was an amazing adventure for me and I met some amazing people, the first night was the most challenging as we were on night watch but when I got used to it I had the best time and learnt so many new things, it really boosted my confidence levels. I have never done anything like this before and I loved every second of it, even when there was poo on deck. My favourite bits were climbing the rigging and exploring Brugge with friends. Oliver M Y8

The trip was amazing, the food was good and the day in Brugge was great, My favourite part of the trip was making friends with people from different year groups and my 4am watch. Thank you to Harry my watch leader and Jazz. It was an amazing trip. Fin C Y8

Sailing Trip

Insight to the Tall Shipp's Race by Charley B, Year 11

My name is Charley and I am a year 11 student at APHS and I was fortunate enough to be chosen to participate in the Tall Ships race 2023 on the boat Excelsior. This was a wonderful experience that I will be remembering for the rest of my life. A few highlights of the trip for me were arriving in Den Helder in Holland and sailing back to Hartlepool. Both of these places had wonderful crew parades and excellent attractions for all the crew members. One of the most notable moments was when we had to sail through a storm in the North sea where the boat was rocking at a 45 degree angle and waves were splashing overboard - we even lost the washing up bowl and the chimney!

The Tall Ships race is a multinational race that has been going on for many years. It involves countries from all over the world including Europe, Africa and Asia. The race of 2023 this year included boats from Indonesia, Uruguay, France, England, Holland and many others - it involved over 60 boats and 2500 crew members in total, 1000 of those, much like I, were trainees.

This was a wonderful opportunity that was presented to a handful of year 11 students that I'm very grateful to the school for organising and I would like to thank the teachers and the crew that were on board on behalf of the students.



Sailing Trip

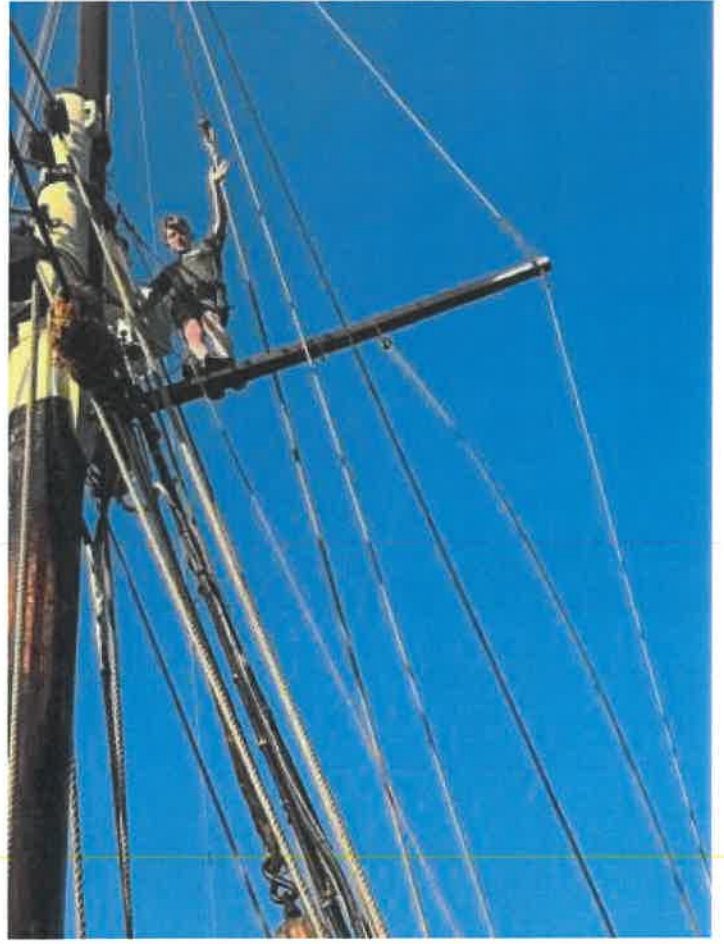

Sailing Trip

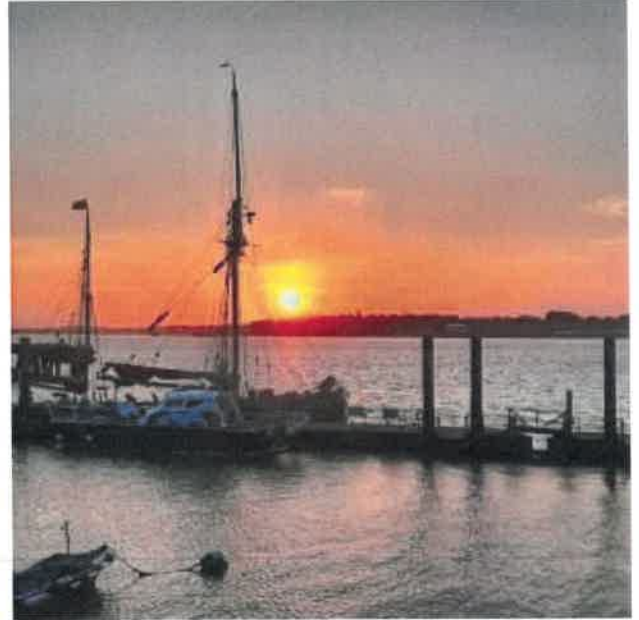

Sailing Trip

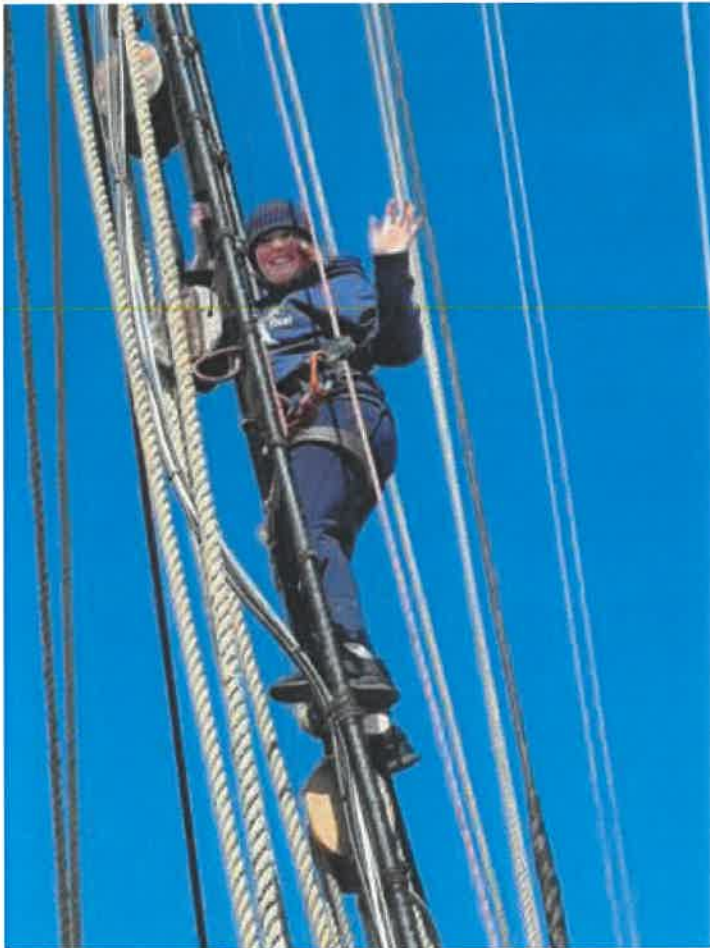

FixUp Team

We had the pleasure of the The FixUp Team working with Year 9 and Year 10 students for the day earlier this term. "Unlocking Potential, Achieving Success" students were inspired and ready to take on their GCSE's in the upcoming years.



Little School BIG DREAMS

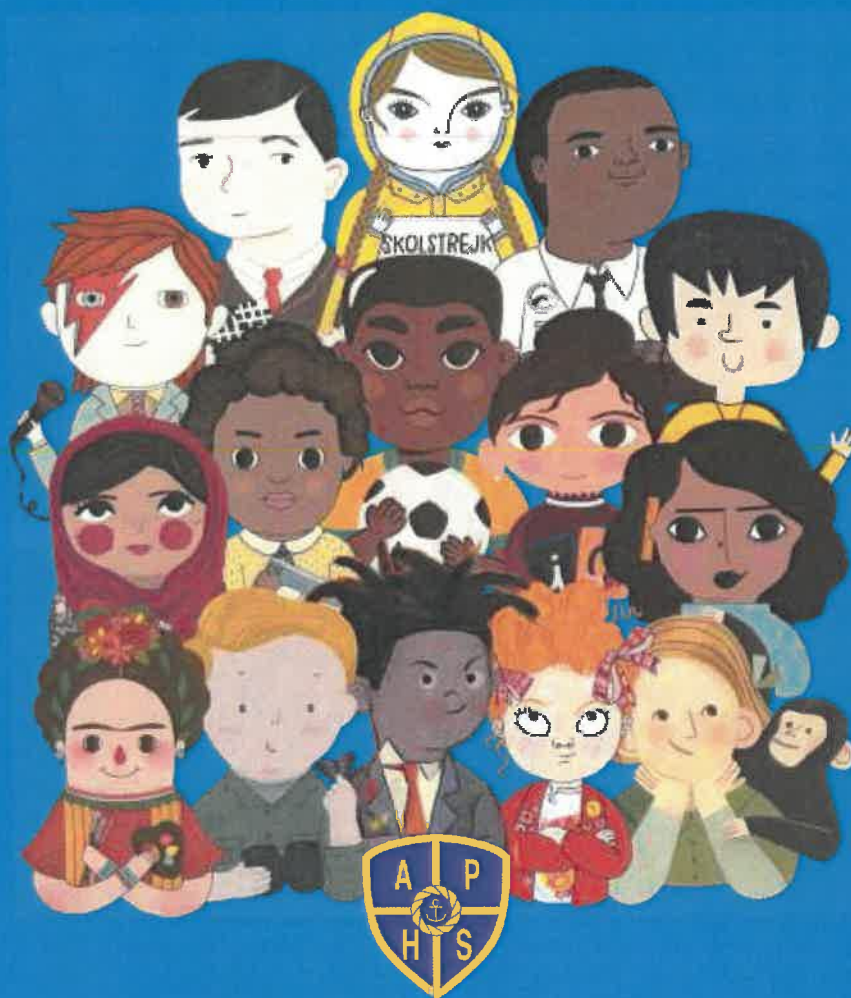

The A.P.H.S. Celebration of
Academic Success 2023

Celebrating excellence, achievement, commitment & endeavour in school

Tuesday 4th July 2023 at Holkham Hall

HOLKHAM

WENSUM 

APHS Academic Awards

Little School BIG DREAMS

MARY RYE AWARD FOR EXCELLENT VOCATIONAL PROGRESS



Lily

Lily is quite frankly a vocational powerhouse. Studying three vocational courses at APHS and manages her time effectively, taking everything in her stride. She has exceeded her target grades in all three of these subjects as well. Well done, a true deserved winner.

Sponsored by the Answorth family, Sarah, Gary and Don and presented by Ben Answorth, Teacher of Travel & Tourism, Health & Social Care and RS

WELLSHAM

Little School BIG DREAMS

THE MARCUS FRENCH ENGLISH BACCALAUREATE



Sydney

A young lady who has a special flair for languages and always goes the extra miles. She does a lot of independent work and is always seeking new ways of practising and improving.

Sponsored and presented by the Wrought Iron and Brass Bed Company

WELLSHAM

Little School BIG DREAMS

THE WROUGHT IRON AND BRASS BED COMPANY FOR VOCATIONAL STUDENT EXCELLENCE



Ellie

Ellie has been phenomenal studying both Travel and Tourism and Health and Social Care. This year alone, she has achieved two very high distinction grades in both these subjects and is on target to achieve the highest grade a Distinction overall. One to watch. Well done*

Sponsored and presented by the Wrought Iron and Brass Bed Company

WELLSHAM

Little School BIG DREAMS

STEM KS3



Jorja

Jorja has shown amazing commitment and enthusiasm in DBT & STEM subjects. She has excellent creative and problem solving skills. She won the Engenuity Skills Award and regularly attends our STEM Club.

Sponsored and presented by the Wrought Iron and Brass Bed Company

WELLSHAM

Little School BIG DREAMS

STEM KS4



Joel

For demonstrating a mature, determined approach in DBT and STEM subject lessons and for regularly sharing his enthusiasm and knowledge by supporting and encouraging his peers in our STEM kit car club!

Sponsored and presented by the Wrought Iron and Brass Bed Company

WELLSHAM

Little School BIG DREAMS

SCIRA AWARD FOR STEM (SCIENCE, TECHNOLOGY, ENGINEERING, MATHEMATICS)



Greenpower Kit Car Club Team

A talented and enthusiastic group of students that have worked incredibly hard all year to design, build and race our Electric Kit Car! They have all shown great teamwork, dedication and commitment!

Sponsored by Wells Carnival Committee and presented by Amanda Moffat, Wells Carnival Committee and Keiran Scillitoe, Scillitoe Bros Garage, Owner

WELLSHAM

APHS Academic Awards

Little School BIG DREAMS

THE CHURCHES IN WELLS AWARD FOR RELIGIOUS STUDIES



Isabella

Isabella has shown such devotion to learning especially within Religious Studies. Her thirst for knowledge has been infectious to those around her, taking others with her as she makes a huge difference to the school at such a young age.

Sponsored by Pinewoods and presented by Becky King, Operations Manager, Darren Williams General Manager & Kayleigh Cadamy Reception Manager

©2018, BHAM



Little School BIG DREAMS

THE ALASTAIR OGLE OUTSTANDING PERSONAL DEVELOPMENT AWARD



Dylan

Dylan has proven at the turn of this new year that he can be the intelligent, driven young man we know he is. Shining in many subjects and his name coming up in positive conversations is something we are proud of and look forward to seeing even more of in Y11. Well done.

Sponsored and presented by Miss Chloe Beech, Head of Expressive Arts

©2018, BHAM



Little School BIG DREAMS

THE NEIL THOMPSON BOATS HORIZON AWARD



Naya

Naya has been on a fantastic journey with us since joining APHS. She has one of the most improved Attitude to Learning scores in the school. She is a wonderful role model for younger students, demonstrating exactly what it means to step up, change your mindset and make things happen.

Sponsored by Thompsons Boats and presented by Mr Neil Thompson

©2018, BHAM



Little School BIG DREAMS

ARTS FOR ALL INSPIRATION AWARD



Bethany

Bethany is a shining light in the Performing Arts who is dedicated to her art at every opportunity in and out of school. A very talented, yet very modest, young lady who sets the bar very high for all other students. A true inspiration to those around her.

Sponsored by Thompsons Boats and presented by Mr Neil Thompson

©2018, BHAM



Little School BIG DREAMS

THE ARTS SOCIETY GLAVEN VALLEY GOLDEN PALETTE ART AWARD



Bonita

From year 7 Bonita has shown a passion, keen interest and commitment for the subject through outstanding class and homework, art club attendance and winning competition entries. She is a truly creative role model to her GCSE class, has a delightful manner and is exemplary in behaviour and attitude. Bonita is never afraid to answer or question to better hers and others understanding of the task or subject.

Sponsored by The Arts Society Glaven Valley and presented by Mr David Riddle, Chair of Governors and Member of the Society

©2018, BHAM



Little School BIG DREAMS

CREATIVE WRITING PRIZE



Matilda

When each movement, sight and sound is considered carefully, to take the reader on a journey, you have become a writer. One day, we may read the words: Author - Matilda.

Sponsored by Bailey, Bird & Warren Estate Agents and presented by Nick Bird, Owner and Polly Carmichael, Negotiator/Listener

©2018, BHAM



APHS Academic Awards

Little School BIG DREAMS

THE TRACY LEAR MATHS AWARD

Logan



Tracy Lear was the Maths Department's first specialist Teaching Assistant. Tracy was a champion for students who struggled with maths and she devoted herself to helping students gain confidence and skills in a subject that many find challenging. Tracy, above all, appreciated a trier - someone determined to improve and achieve, no matter how hard they find the going. The Tracy Lear award recognises the fact that effort is never wasted.

Sponsored by French's Fish Shop and presented by Tracy's colleagues and dear friends in the Maths Department

PHOTOGRAPH



Little School BIG DREAMS

ROYAL BRITISH LEGION FOR SERVICE TO THE SCHOOL

Yvie



For the past four years, Yvie has immersed herself in school life and made valuable contributions to a variety of school activities and organisations, including Eco Council, Student Parliament, Open Evenings and achieved the Duke of Edinburgh Bronze Award while previously a Wells Sea Cadet. An exceptional young person.

Presented by David and Mary Woolgar, Royal British Legion

PHOTOGRAPH



Little School BIG DREAMS

WELLS & DISTRICT LIONS CLUB COMMUNITY YOUTH AWARD

Oliver



Oliver is involved in many aspects of the community supporting the Expressive Arts Department in performances and representing in Sea Cadets in many ventures; all with a massive smile on his face. His positive attitude is contagious and inspired those around him to be even better.

Sponsored by G Sands and Son and presented by Amanda and Fred Sands Director/Partner

PHOTOGRAPH



Little School BIG DREAMS

PAM THOMSON AWARD FOR SERVICE TO THE SCHOOL

Ed



Ed is an exceptional young man. As a leader of the school Eco Council, he has implemented a number of initiatives to help the school and local environment for future generations, even producing videos and resources for other young people. As the new Head boy, the future is bright.

Sponsored by G Sands and Son and presented by Amanda and Fred Sands Director/Partner

PHOTOGRAPH



Little School BIG DREAMS

SILVER CLEF COMPOSITION AWARD

Alex



A very talented musician, Alex proves time and time again that he is able to create fantastic work in class at the highest of levels. A worthy winner of this award and a very bright talent for the future.

Sponsored by Hayes & Storr Solicitors and presented by Stephanie Connor and Laura Weston, Lawyers

PHOTOGRAPH



Little School BIG DREAMS

MW CLIFFORD PERFORMANCE AWARD

Iryna



Iryna has demonstrated outstanding effort and achievement in music during this academic year. During her musical journey this year, Iryna has won first prize at the EPFA Piano Competition 2023 and proceeded to perform on the piano in London. Дякую за музику

Sponsored and presented by Adam Watson, Power Pros

PHOTOGRAPH



APHS Academic Awards

Little School BIG DREAMS



FAKENHAM GARDEN CENTRE GREATNESS IN LEADERSHIP



Eli

Respected, talented and the perfect role model, Eli always leads by example. Has the highest of standards and brings others with him. He has had a hugely successful year on and off the sports field and is an absolute superstar!

Sponsored and presented by Adam Watson, Power Pros

WILLIAMHAM

Little School BIG DREAMS

THE CHRIS COUBROUGH MOST ABLE, GIFTED & TALENTED ACADEMIC HONOURS AWARD



Oliver

The winner of this award is someone who is highly thought of across the school and has no fewer than 9 subject nominations for being a Most Able, gifted and talented student! This ability to excel in a variety of subject areas whilst still being eager to improve and committed to school life is testament to this young man, his family and the support network he has around him. We look forward to seeing him progress even further in KS5 and thank him for all his efforts in and outside of school.

Sponsored and presented by David Riddle, Chair of Governors



WILLIAMHAM

Little School BIG DREAMS

HEADTEACHER AWARD FOR SCIENCE



Sydney

Sydney is an exceptional student whose academic achievements, unwavering work ethic, and positive attitude have earned her the prestigious Head Teacher Award for Science. Her dedication to science, coupled with her outstanding performance, sets a remarkable example for her peers and showcases her commitment to excellence.

Sponsored by Monica Vinader



WILLIAMHAM

Little School BIG DREAMS

HEADTEACHER AWARD FOR ENGLISH



Alex

Your approach to English is further than above and beyond; your focus to achieve absorbs more than the words in the class; your ability to create a buzz about characters and ideas is inspirational.

Sponsored by Pinewoods and presented by Becky King, Operations Manager, Darren Williams General Manager & Kayleigh Cadamy Reception Manager



WILLIAMHAM

Little School BIG DREAMS



HEADTEACHER AWARD FOR MATHS



Sydney

Sydney demonstrates a real talent for maths - not only at GCSE, in school, but also following a Further GCSE course through the Sir Isaac Newton Sixth Form Outreach programme. She has made terrific progress this year and we confidently expect her to achieve top grades in both qualifications next year. A thoroughly deserved recipient of this award.

Sponsored by Monica Vinader

WILLIAMHAM

Little School BIG DREAMS

THE JIM FARRINGTON UNsung HERO AWARD



Scott

A wonderfully positive and polite young man, respectful, hard working and genuine. Scott shows that a simple act has huge and lasting implications for all aspects of school life. He is a role model for all. He is a great role model for his peers. There is a shining star in the school and he offers others to complete tasks on help that without being asked which helps him spend our hours in years. Most recently the team are striving to complete the 100 year challenge.

He keeps the school clean and tidy by day after day and supports the Y7 & 8 reward system and ensures that every boy has the best of the best. He is the best of the best.

We never stop anything for an instant toward he does it because he wants to help. The perfect embodiment of the message we give to all APHS, "He does the right thing, even if nobody is watching!"

Sponsored by JD Cooling Group and presented by Kirsty Kern, Group HR Supervisor



WILLIAMHAM

APHS Academic Awards

Little School BIG DREAMS

FAKENHAM HEEL BAR AWARD FOR EXCEPTIONAL ATTITUDE TO LEARNING



Raphael

Raphael is an absolute pleasure to teach. He is conscientious, hardworking and thoughtful about what he does. The standard of written work, practical work and homework is also superb and he has made excellent progress as a result. A young man with an excellent future ahead of him.

Sponsored and presented by Matt Hardman, Principal

FAKENHAM



Little School BIG DREAMS

THE WENSUM TRUST ENDEAVOUR AWARD



Charlie

Charlie has always worked hard and is now reaping the rewards. He does not always find everything easy, but he has shown that perseverance and determination is always a recipe for success. Now rising to the role of senior prefect and we could not be more proud.

Sponsored by the Wensum Trust and presented by Daniel Thrower, CEO Wensum Trust and Anne Oakley, 'The Place' SEMH Base Lead, Wensum Trust

FAKENHAM



Little School BIG DREAMS

HOLKHAM ESTATE ACADEMIC STUDENT OF THE YEAR



Kaitlin

A kind, diligent and emotionally mature young lady who is supportive to all of those around her

An unassuming superstar, always smiling, polite, and a pleasure to converse with.

Considerate, committed, kind and driven.

Polite, thoughtful, conscientious and always willing to help.

An academic powerhouse who is always willing to support anyone, whether staff or student, big or small task, Kaitlin is the person you rely on.

Kaitlin immersed herself in the Wells Matings, King Charles Art competition creating an award winning piece, even though she is not studying the subject at GCSE!

A remarkable young lady - not only fiercely intelligent and conscientious but unwaveringly thoughtful, funny, helpful and kind. One of a kind!

Discreetly wonderful!

One of the most intelligent, kind, sincere and inspirational young ladies I've ever had the privilege to teach.

Presented by Niamh Walter, Weddings & Events Manager, Holkham

HOLKHAM



APHS Academic Awards

With special thanks to:

Our Event Sponsors

ETS Lighting & Sound
Holkham Estate
I do photography
School Merit Stickers
Thaxters Garden Centre
The Crown Hotel, The Flying Kiwi Inns

Our Prize Sponsors

Adam Watson Power Pros
Arrowsmith Family; Sarah, Gary and Ben Arrowsmith
Bailey, Bird & Warren Estate Agents
Chloe Beech, Head of Expressive Art
Christine H Hardman Ltd
Copper Kettle
David Riddle, Chair of APhS Governors
French's Fish Shop
G Sands and Son
Hayes & Storr Solicitors
JD Cooling Group
Matt Hardman, Principal
Monica Vinader
Neil Thompson Boats
Pinewoods Holiday Park
PiXL Partners in Excellence
Power Pros
Royal British Legion
The Arts Society Glaven Valley
Wells Carnival Committee
Wells & District Churches Together
Wells & District Lions Club
Wensum Trust
Wrought Iron and Brass Bed Company

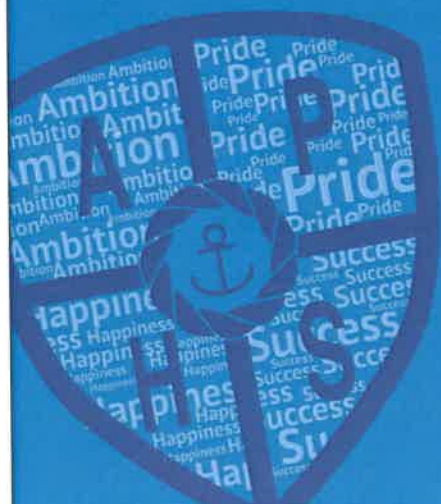

Alderman Peel High School
Market Lane
Wells-Next-the-Sea
Norfolk NR23 1RB
01328 710476
office@aldermanpeel.norfolk.sch.uk

WENSUM TRUST



MONICA VINADER



G SANDS & SON



Neil Thompson Boats



HOLKHAM

APHS Highlights of the year

ENGLISH

- A group of pupils went to Norwich Cathedral for a GCSE workshop led by the famous author, Louis de Bernieres. Having a lesson in this wonderful setting was a unique experience.
- Year 9s wowed their teachers with their amazing 2D and 3D representations of novels that they have been reading; the creativity was mind-blowing!
- More classes have enjoyed the 'speed dating' of books at the end of terms; this has helped them decide on potential next books they wish to read.
- KS3 have tackled a variety of centuries in their learning, from Shakespeare to modern novels; Year 7s are finishing the year by visiting the weird and wonderful world of Alice in Wonderland.
- Year 8s thoroughly enjoyed being bewitched by Macbeth, hooked in suspense by The Speckled Band and are finishing with tough lessons from history and of American life during the Great Depression in Of Mice and Men.
- Year 9s are completing a full year with their first GCSE Literature text - Romeo and Juliet.
- KS4 have worked really hard to recall and remember the many elements within their Literature texts alongside polishing their language writing skills and ability to respond to questions on GCSE texts.

MATHS

- After a spellbinding series that never loses its appeal, all Year 7 students now know the identity of The Factor!
- Year 8 students were engaged in a fantastic Origami workshop led by Mr Beaumont.
- Year 9 students have worked incredibly hard this year in preparation for the start of their GCSE course.
- And we are anticipating a bumper set of GCSE results this year

SCIENCE

- The Science fair was amazing, as always, with all pupils demonstrating a high level of understanding of their chosen topic.
- APHS students continue to work hard in Science and some achieve magnificent results, but all that try to do achieve their goals

FRENCH

- This year saw the largest intake in Year 10 French GCSE, for the fourth year in a row.
- Gifted and Talented Year 10 linguists were given the opportunity to tackle authentic material to practise their reading and listening skills.
- Year 9 and 10 completed a series of culture lessons on French music and French television series.
- Delighted to be heading to the Dordogne this year as part of our dual-country MFL trip - it will be a fantastic trip and our first since Covid. It will be wonderful to see the language come alive for our young people. Carcassonne in 2024!

LEARNING SUPPORT

- We're delighted by the year our students have had, with young people embarking on adventures such as the Excelsior sailing ship, paid and voluntary work, representing the school at the Norfolk Show and going off to a variety of colleges to continue their adventures.
- Highlights for us include watching our students win awards and recognition across the school and beyond despite the things they find tricky, lots of cake, laughter, singing, Pokémon, Lego and formal debates on the future of seagulls(!).
- A special well done to our own Mrs Long and Miss Cowell who are moving more and more into the classroom as teaching members of staff. We know you'll be fantastic!

ACHIEVE

- Our first cohort of students achieving a 100% pass rate, with one student being specially commended by the exam board for exemplary work above and beyond the expected standard.

SPANISH

- Spanish remains a popular option with the largest GCSE group ever this year - but it looks as though we'll beat this record next year!
- Blooket club has been a roaring success and it's great to see our keen linguists having fun with the language.
- Delighted to be heading to San Sebastian this year as part of our dual-country MFL trip - it will be a fantastic trip and our first since Covid. It will be wonderful to see the language come alive for our young people. Barcelona in 2024!

APHS Highlights of the year

GEOGRAPHY

- This year we have enjoyed being able to get out and about again!
- Year 10/11 completed their coast fieldwork in West Runton on a beautiful, sunny day in October!
- Year 9 learnt how to profile slopes outside as well as carrying out Environmental fieldwork in the summer term.
- Year 8 revised their six figure grid references by deciding the most appropriate places for a weather station and will carry out traffic surveys in Wells in the summer.
- Year 7 have learnt six figure grid references outside, made their own river basins and will complete pedestrian fieldwork in the summer. 28 students got to visit Snowdonia and had a wonderfully sunny trip in April! Next year's Snowdonia trip has already been booked.
- Finally, 50 students visited Birmingham as part of their GCSE

HISTORY

- Year 7 have settled really well and have worked incredibly hard on their topics of the Romans and the Normans. We've had some fabulous castle models and some gruesome accounts of the Black Death.
- Year 8 have explored one of History's most famous royal families - The Tudors and they've researched what happened to Oliver Cromwell's head. They have approached their studies on Slavery and Black Civil Rights with the highest level of maturity and understanding
- Year 9 have proved themselves to be worthy historians, through their studies of the Industrial Revolution, the development of democracy and 20th century conflicts. History has proven a very popular choice at GCSE.
- Year 10 have approached their GCSE History units with dedication and enthusiasm. Their exam skills are coming on leaps and bounds and we are so excited to see the progress they make next year in the lead up to their exams

FOOD TECHNOLOGY / HOSPITALITY AND CATERING

- Record number of first choice this year for the next Y10s and 11s.
- Y10s dedication and commitment to the subject ran through the year, the best GCSE group so far.
- The level of quality and the complexity of dishes from the Y9's "APHS great cooking competition", was outstanding
- Unrelated to the subject, having the opportunity to share my culture with students and colleagues during the Ski Trip in Italy has been the highlight of this school year (Mr Barison)

PASTORAL

- APHS received the 'Gold Award' for Schools Mental Health from the Carnegie School of Education. This is a highly prestigious award which only a few schools in the country have achieved.
- The APHS Rewards Scheme continues to be a very popular scheme with the students. Students received so many achievement points that we nearly ran out of stock at one point!

RS

- Another great year of good results. We have had our first GCSE cohort in almost 5 years complete their GCSE with results due in August 2023.
- KS3 have investigated new units such as Crime and Punishment and Religion and the Environment.
- A big shoutout goes to Year 7, for their work in making sure their books are always neat and tidy. Some beautiful work has been produced throughout the year.

TRAVEL & TOURISM

- A very successful year for Travel and Tourism. Year 11 have achieved some fantastic grades, however Y10 have absolutely smashed their first PSA's this year, with lots of students achieving 12 out of 12 on their tasks.
- We also successfully ran a residential trip to Paris which 48 students loved and we have already started planning 2024's trip.

APHS Highlights of the year

COMPUTER SCIENCE

- year 7 the students created a fabulous Christmas video. Many of the students learnt some signing and this was added to the video. The video was shown to the whole school before we broke up for Christmas and was a brilliant way to end the term. Well done year 7.
- E-safety ambassadors help produce a presentation for safer internet day. They also helped year 7 make their phones safer, by showing them how to protect their private data.
- Year 11 iMedia continued to show off their superb photography skills, some of this work was displayed at the Maltings and we had several prize winners from the class.
- Computing club continued throughout the year with many projects being worked on during lunchtime and after school. Projects this year included a drone simulator and creating an arcade machine.
- We have entered several competitions, our Lego robotics club recently competed at RAF Honnington, they enjoyed the event and came second in the team work category. It was an interesting and thought provoking visit, the students were shown the work that the RAF do when they provide humanitarian aid and evacuate people from war torn countries.
- Of course, we cannot forget that two of our students from the Lego robotics club competed in the World championships in Estonia. They did exceptionally well. In the next few days, the Lego robotics club will be competing in the qualifiers for the World Championships, we wish them all luck and success.

'My Norfolk Life' Creative Arts Showcase Exhibition at Wells Maltings (10th- 23rd February).

- In January 2023, Year 6 students from Wells Primary & Nursery School were invited to visit APHS to take part in creative workshops. They painted laser cut wooden beach huts in Art and made sail boats using recycled materials such as wood and fabric in Design & Technology. This work formed part of our collaborative student exhibition entitled 'My Norfolk Life' at the Wells Maltings. The preview evening on 9th February was a huge success with almost 400 guests! Those in attendance were wowed by an amazing array of art, design, photography and literature work, performances from our talented drama and music students, delicious canapes made by our hospitality and catering students, plus our Greenpower F24 Kit Car was on display in the foyer! Massive thanks to the following team who made this fantastic event happen: Mrs A Light (Teacher of Art), Mrs A Moffat (Teacher of Design and Technology), Mr T Heron (Teacher of Art and Design), Miss C Beech (Head of Expressive Arts), Mrs L Cowell (Teacher of Singing), Mrs J Cowell (Local artist and volunteer), Mr D Frowhawk (ICT Technician), Mr T Sutton (Site Manager) and to Carolyn Stocker, Isaac Glegg and Simon Daykin from Wells Maltings.

PE

- The 12th Celebration of Sport Awards Evening - which recognises students' commitment and excellence across an array of sports and activities with Tom Youngs, Leicester Tigers, England and British Lions Rugby player as our Guest of Honour.
- APHS Sports Leaders supported the Festival of Sport at Holkham Estate last summer, doing such a good job that they have again requested our assistance at this year's event.
- 108 students attended the Ski Trip to Tonale, Italy. Our biggest overseas trip yet!
- Annual school trip to Welford Road Stadium to watch Leicester Tigers against Harlequins. Supporters were invited onto the pitch after the match to meet the players due to it being the final home game of the Gallagher Premiership season.
- A number of Year 7-9 pupils played in Representative Rugby matches for a Wensum Trust team alongside Acle and Hellesdon students against Vikings teams.
- APHS Sports Leaders have helped to organise and run Primary Cluster competitions in Touch Rugby, Quicksticks Hockey, High 5 Netball, 6-a-side Football, Swimming Gala, Tri-Golf, Mini Tennis, Kwik Cricket and Beach Volleyball.
- Finally, there have been many notable sporting achievements throughout the year, including: U16 Rugby team reaching the County Cup final, U14 County Cricket Champions! U15 Cricket Finalists (Final being played today!) U14 and U16 Netball team 3rd place in their Area Rounds, Several of the Football teams finishing the season unbeaten, A number of students representing APHS at Anglian Schools Cross Country and Norfolk Schools Athletics.

APHS Highlights of the year

DESIGN TECHNOLOGY & STEM

- Greenpower Team Building Challenge Evening (6.10.22): Students who applied to join the Kit Car Club were set a series of problem solving challenges and the winners were invited to join our first ever F24 Team. Our first Greenpower F24 Electric Kit Car Club (20.10.22) kicked off with a grand unboxing of the kit car! Thanks to sponsors.
- Lord Mayor's Parade, London (12.11.22): As Wells-next-the-Sea was the home of the new Lord Mayor of London, Nicholas Lyons, he invited the town's 'Quay Workers', along with students from APHS, to take part in the Lord Mayor's Parade in London. Students who took part had an amazing day waving their own decorated laser cut wooden beach huts and acrylic crab banners at the crowds lining the parade!
- Gresham's STEAM Fair (17.11.22): Year 10 D&T & Art students, along with the Greenpower F24 Team, enjoyed a trip to Gresham's new Dyson STEAM building to see an impressive list of exhibitors and to learn about potential career routes.
- Greenpower F24 Team Trip to Aylsham High School (2.12.22): Our team gained lots of great tips and advice from Mr Bradshaw and his team on our visit to his club. Many thanks!
- Global Enterprise Event (8.12.22): Year 10 were challenged to work in teams to design and make products using recycled plastic bottle tops as part of enterprise week. They then had to market and sell them and raised £52 for the RSPCA!
- Big Potato Games 'Small Fries Inventor Championship' (12.12.22): Year 9 took part in the first Big Potato Games national competition to design and make an original and fun party game. Amazingly, one of our teams came third in the country, with their game 'Animal Mayhem', winning cash prizes and a Big Potato game of their choosing!
- RAF Marham Youth STEM Day (13.12.22): All of Year 7 and a group of Year 8s took part in one of three engaging and fun workshops designed to encourage creativity, problem-solving and team-building skills. Many thanks to Matt Bagley from Camouflaged Learning and @rafyouthengage
- Visit from Jonathan Lynn (12.1.23): Our Greenpower F24 Team were privileged to meet Jono Lynn, who kindly gave a presentation to our team about his inspiring journey from school to working as a race engineer with Aston Martin!
- 3 visits from Leanne Neave, Education and Events Manager for the Mid Norfolk & North Suffolk Branch of the RSCPA (September, January and March): Year 11 benefited hugely from having a real client for their GCSE coursework, which was to design and make a product on the theme of 'caring for animals'. Massive thanks to Leanne, who worked closely with our students to provide them with ideas and inspiration, encouragement and essential feedback on their product concepts throughout their design process.
- Trip to Longlands, Holkham Estate (2.3.23): Year 10 students enjoyed our annual trip to Longlands to learn about sustainable forestry management, the properties of timber and careers on the estate, plus they got to visit the Holkham Forge to learn about welding and forming metals. Big thanks to Sophie, Harry, Steve and the team @Holkham for providing this amazing learning experience!
- Design and Build a Virtual Wind Farm Day (7.3.23): A class of Year 8 students were challenged to design and build a virtual wind farm off the coast of North Norfolk using specialist 3D software and VR headsets. Massive thanks to 3DW for sharing their knowledge and expertise with our students and to Orsted for funding the workshop.
- Enginuity Skills Award (15.3.23): Congratulations to Jorja (Year 7) for designing the winning entry in the Enginuity National competition to design a table centrepiece. As part of her prize, Jorja received a cash prize, a design engineering book, a Spero Bolt and her and a class of Y7 girls will take part in a free Spero Bolt coding day workshop at APHS on 10th July to learn about coding and robotics worth £960!
- RAF Marham STEM Day (21.3.23): All of Year 8 worked in teams to complete a series of 'Construction Challenges' using giant Meccano kits as part of a team building and problem solving exercise. Big thanks to Andrea, Paul and Gaz from RAF Marham.

APHS Highlights of the year

- Hunstanton Soapbox Derby (2.4.23): Congratulations to Tom (Year 9), a member of our Greenpower F24 Team, for coming second in his age group in the Hunstanton Soapbox Race in April in his Top Gun themed go-cart! King Charles' Coronation Bunting (5.5.23): Year 10 had fun block printing coronation bunting as part of their textiles unit with right royal results!
- Trip to Bill Cleyndert & Co (31.3.23): Year 10 students enjoyed our first trip to Bill Cleyndert bespoke furniture manufacturer to see their timbers theory being practised in a commercial context. Congratulations to Chelsey Church (Year 11) for gaining an apprenticeship with Bill Cleyndert & Co. starting in August, following her successful work experience placement with the company last year.
- Greenpower F24 Team Trips to Scillitoe Bros Garage (May-June): Keiran Scillitoe and his team came to our rescue and collected our kit car so that our engineering team could continue working on getting the car race ready at their garage each week (even during half term) thanks to their expert help and guidance!
- Local Logo Design Competitions (18.5.23): Students were challenged with designing a logo for the newly formed 'Little Gillies Nursery' for 0-3 year olds. Well done to Mollie and Maxwell (Year 9) for their winning entries which were combined to create the new logo. And well done to Izzy (Year 9) for creating the winning design for Burnham Market Nursery School's 50th Anniversary logo which incorporated key aspects of their new outdoor learning area.
- Trip to NUA 'Gradfest23' Degree Show (16.6.23): Year 10 enjoyed an inspiring trip to Norwich University of the Arts Degree Show, which included outstanding work by students studying Animation, AVFX, Interior Design, Architecture, Graphics and illustration. We look forward to welcoming Sen Thompson from NUA who is coming to APHS to run an animation workshop for Year 9 & 10 students interested in game design on 18th July.
- Greenpower F24 Team Regional Race Day (25.6.23): Our team had an amazing day out at Lotus Test Track in Hethel, Norwich, racing our kit car against other school teams in the Greenpower Regional Event. We ended the day coming 21st out of 38 which was a fantastic achievement for our first time. We also won the award for best 'Portfolio' which we created to document our amazing journey over the past year! Well done to all of our team and thank you to all our sponsors and to everyone who has supported our club, especially Mr Frowhawk (ICT Technician) and Mr Sutton (Site Manager) who have worked alongside the students all year and massive thanks has to go to Keiran Scillitoe and his team at Scillitoe Bros Garage for their amazing help over the past 2 months, without which we would not have got the car finished in time! And the great news is Keiran is keen to continue supporting our club next year and already has plans for making our second kit car even better! Finally, congratulations to Sam Pickard (Year 10), our team leader, who gained a week's work placement at Lotus Cars!
- Trip to Sizewell B Nuclear Power Station (5.7.23): A group of Year 9 students will be going to Sizewell B to learn about nuclear power and careers in the energy sector thanks to EDF Energy.
- Big Bang in school STEM day (11.7.23): All of Year 7 will be taking part in a number of workshops including a boat design workshop thanks to Neil Thompson Boats, a VEX Robotics workshop thanks to James Clarke at Hethersett Academy and 2 workshops thanks to Energy Quest where students will learn how to use fruit to power mobile phones!
- D&T/STEM CLUBS: CAD CAM CLUB and STEM KIT CAR CLUB weekly

PSYCHOLOGY

- In their first year of studying Psychology, year 10 students were introduced to several exciting topics providing them with a deeper understanding of the human mind and behaviour. Here are some highlights from the course:
- Research Methods: Students delved into the research methods used in psychology, learning about experimental design, statistical analysis, and ethical considerations in conducting psychological research.
- Cognitive Psychology: This branch of psychology explores fascinating topics such as memory and perception. Students examined theories on how information is processed, stored, and retrieved, including the multi-store model of memory and the role of schemas. They also learned to question whether they can believe their own eyes, as they analysed a range of mind-bending visual illusions!
- Developmental Psychology: Students explored how individuals develop physically, socially, and cognitively across their lifespan. They studied influential theories such as Piaget's stages of cognitive development and learned to evaluate recent studies in education on the benefits of adopting a 'growth mindset'.

APHS Highlights of the year

DRAMA

- The GCSE Drama class of 2022 produced absolutely fantastic outcomes whose overall progress put them in the top 1% of the whole country. 50% of students achieved the very top grades of 7-9
- Two amazing evenings of entertainment in our annual whole school production. A Night at the Musicals was performed by over 200 students in the school and sold out for both nights!
- KS4 MAGT and Y11 Drama students performed 'Extracts' at Wells Maltings in March. The evening of acting from modern and classic texts was performed by 29 students in front of two sets of audiences and was extremely successful in its reviews. There were extremely mature displays of acting in the chosen extracts including Prima Facie, 222: A Ghost Story, DNA and Top Girls
- Y8&9 Phase Club students performing short pieces of original and scripted drama at the Creative Arts Exhibition, Wells Maltings
- Wells Maltings Theatre trips for all years to see Time and Tide produced by Relish Theatre and Tapped produced by FiveOFresh
- The first Y7 and Y8 'green effort badge' trip to see the incredible Unexpected Twist with all Expressive Arts teachers at Norwich Theatre Royal attended by over 40 students. For lots of students this was their first time at the theatre or first drama they had seen live
- Y7-10 Drama trip to see the magical Charlie and the Chocolate Factory at Norwich Theatre Royal
- Y9, 10 and 11 MAGT theatre trip to see NNOS Kinky Boots at Norwich Theatre Royal
- Y8&9 trip to see FADLOS' Little Shop of Horrors in Fakenham
- Y11 Drama trip to see the intense, 222: A Ghost Story at the Lyric Theatre with Cheryl Cole and Jake Wood as leading actors
- National Theatre Live performances of The Crucible and Fleabag attended by Y8, Y9 and Y10 students
- 'Careers in Media' discussion panel trip at the Auden Theatre, Gresham's, including an international producer from Monumental Pictures and seasoned stage managers of West End theatre. A very inspiring afternoon
- The annual Blood Brothers trip at Orchard Theatre, Dartford for Y10 and Y11 in November, and at Norwich Theatre Royal for Y9 students in June
- Many students celebrating performances outside of school including Jason and the Argonauts with Creake players and Alice in Wonderland with King's Lynn players youth company and ex-student showcases at College of West Anglia in their prospective Musical theatre courses; all attended by staff and students from APHS
- Graduate success: Hannah Besant (Alumni 2020) achieved her first acting contract at the London Dungeons and George Giles-Loane (Alumni 2016) producing and directing his first short film: Internal Bleeding
- Drama students and Prefects supporting the launch of the new Wells Maltings Youth Club, along with giving a speech in front of the public
- Drama students and Prefects supported three discos over the course of the year
- Y10 workshops on Frantic Assembly, Paper Birds and Forced Entertainment to support with their upcoming devising work in which the group have been absolutely fantastic to work with this year
- Y7&8 Drama Club and Y9 Phase Club continue to run with popularity
- Our very own Miss Cowell will start her official teacher training with us in September having already completed two successful years in instructing

RESIDENTIAL

- Year 7 Hilltop Residential Visit was a phenomenal success at the start of the Academic Year, and allowed Year 7 to make an excellent transition into Secondary School.
- Excelsior Sailing Trips. Due to the generosity of The Excelsior Trust, Norfolk Boat, Neil Thompson Boats and The Langley Foundation. We secured nearly £20,000 to give 30 students the opportunity of a lifetime. 3 trips in total, including a UK coastal trip, A trip to Belgium and a Celebratory Y11 reward trip to Den Helder to take part in the prestigious Tall Ships Race. The Langleys are a sailing family who live in Blakeney, they have their own professional racing team in the TP52 class.

APHS Highlights of the year

ART

- It's been a busy and rewarding year for the Expressive Arts Department in all our ventures in and outside the classroom providing a plethora and wealth of cultural experiences as seen below for Art, Drama and Music:
- It's been a great year of APHS Art exhibitions and gallery trips, with lots of after school workshops: in Drawing, Painting and Ceramics and we all loved having our wonderful visiting artist, painter, Jo Cowell who worked with our Year 8's on their fabulous, large scale water paintings.
- We have also had some very generous donations to the department this year from parents to local businesses, including wonderfully illustrated art books, huge painting canvas' from the lovely folks at Walsingham's of Wells and some fantastic picture frames, including the wonderful sponsorship of grand, large scale recycled frames for our exhibitions of APHS student work, generously donated by Picturecraft of Holt.
- In October we were invited to create a very exciting and large scale, whole school exhibition and competition at the fabulous Wells Maltings Gallery. The theme for the showcase was 'My Norfolk Life' and in February this year many students from across all year groups were invited to exhibit their beautiful artwork in the stunning Handa Gallery on Staithe St. Our young artists created pottery vessels, abstract sea paintings, beach scenes and created images and photographs of their local beaches, friends, favourite events, such as the carnival and Pride, plus recreating our woods and special walks through painting, drawing and printmaking. Thank you to all who attended and made the Creative Arts Showcase Evening and week long exhibition such a fabulous and well attended event. VIP guest judges and a People's choice voted awards meant that many of our students received prizes and recognition for their exciting and meaningful work, some of which can be seen tonight on display. Martha S, Ruby B, Bonita E, Sophie L, Chelsea R, Cicely T and William S, Rhys B and Naya-Jayne A and Zenepe F were amongst many of the talented KS 3 and 4 students, to be nominated for People's Awards and VIP judges Awards.
- 'Breaking News': Fashionista Zenepe F and her incredible Year 9 team of 'Fashion Assistants' led the way at lunchtimes to create a beautiful Wedding Dress, called 'Breaking News!' made from recycled newspapers and plastics. The design was created for the Microsoft sponsored 'Junk Kouture' world eco-fashion competition for budding designers. The age category was from 13-18 age range and the girls made it to the London UK catwalk finals, with their creation which is on show tonight. These Year 9 girls were up against first year fashion degree students across the UK, making this an incredible achievement on a par with our recent Royal Academy Summer Show win, out of 33,000 applicants.
- In April, every child in the school was invited to take part in an art competition to honour the Coronation: it was called 'Prince to King Charles' and this culminated in a Wells community event at the Maltings, an exhibition of APHS portraiture, over the Coronation weekend in May. Well done to Judges Choice winners: Harry H, Bonita E and Evie D. Runners up were: Amber R and Oliver H. People's Choice winners were: Will S, Charlie Peters and Ruby B and Jacob T, Kaitlin P, Alexa O, Mallory G and Erin H-B.
- In October, we had a busy and creative day working alongside local Year 6 students from Wells Primary. We explored our local coastline and our famous beach huts, using laser cut wooden huts the young students created their own colourful designs to decorate them. They then worked between art and DT to create wooden sailing boats with found branches and recycled fabrics. We hopefully built the start of relationships and helped boost confidence as the 11 Year olds prepare to come to APHS in September.
- The Sainsbury Centre for the Visual Arts continues to be a wealth of world art and sculpture, with resources and ideas for the children to take inspiration from. Our recent trips have seen the students enjoy sketching in the free galleries of the Sir Norman Foster (think Gherkin, London) designed building and visiting the famous sculpture park, all nestled in the beautiful grounds of the UEA. We are very excited to take our budding current Year 9, pre-GCSE students, there in September

APHS Highlights of the year

MUSIC

- APHS received the Music Mark Award for schools back in November in recognition of the school's commitment to providing musical education which we are very proud of.
- House Music competition in October with the theme 'film classics' - well done to Waveney House being the winners
- Singing masterclass from Michelle Wolfe (Director of Music at Greshams and ex-teacher here at APHS) for the choir ahead of the Candlelight Musical Tour Concert at Holkham Hall
- Christmas Tide sing-a-long at Wells Maltings led by Miss Beech and Miss Cowell was a perfect way to start off the holiday season with many of our Expressive Arts students taking part singing and/or playing solo
- The Candlelight Musical Tour and Concert at Holkham Hall in association with Gresham's School was a beautiful and grand affair which saw many of our singing students perform solos, duos and small group ensembles around the stunning rooms and then in the Marble Hall for the concert itself. It was a wonderful evening where voice was really celebrated
- Arts Award Bronze performance from local duo Sons of Mark
- Group ensemble performances at The Creative Exhibition in Wells Maltings in front of big audiences
- Students performed at many venues with our Lead Peripatetic Teacher Mr Howell and piano teacher Mr Preston. These included, Bagthorpe Hall, Thornage Church Carol Service and Bircham Windmill
- Musicians took part in the EPTA Piano Competition, Norfolk Region at Gresham's hosted by The Missing Coda. Iryna O, Y8 was one of the winners. Iryna also performed in the Rotary Young Musicians day 2023 in King's Lynn and The Norfolk Show
- A fantastic afternoon welcoming the Sheringham Shantymen and their brilliant interactive workshop with the whole of Year 8 and other KS3 students
- Cantabile Choir was set up by Mrs Ballard and they are part of the entertainment you see in tonight's programme
- Miss Cowell and Mr Howell led choir to success in performances at St Andrews Hall for the Norfolk County Music Festival which was 'highly commended' and Y6 Open Evening
- Piano workshop at Fakenham with five students from Y7-9
- Music Theory continues to grow in popularity on Fridays, with many students taking theory grades as a result of this and grades in their instruments in their peripatetic lessons. Some results include grade 4 and above in piano, grade 5 in guitar and above, well done all!
- We welcomed Josh Bush (Alumni 2020) as peripatetic guitar teacher and we welcome Mr Lott as Music teacher from September

HEALTH & SOCIAL CARE

- This is a new course to APHS this year and the students have been absolutely exceptional. They have taken to KS4 learning like a dream and have produced some fantastic grades in their Component 1 PSA. We are currently working on their second component in hopes of starting this coursework in early October. We also like to thank Junior Sister Simone Nuccoll from the Neonatal Unit QEH in Kings Lynn for her support earlier on in the year when she came and spoke to students about what it was like to be a nurse for premature babies. The students were truly inspired by her words of wisdom.

WENSUM TRUST STRATEGIC PARTNERSHIP

- The Strategic Partners for the Wensum Trust have delivered some outstanding experiences for our students.
- The Wells Sea Cadets have moved from strength to strength and could have their own 50-page booklet of highlights.
- The partnership with Norwich theatre has brought a new collaboration with the Royal Shakespeare company to enrich our English and Drama Curriculum.
- North Walsham Rugby club have provided high quality coaching and competitive Rugby for boys and girls across a range of year groups.
- We are looking forward to seeing these partnerships develop even further for the benefit of our students.

Olympeel Games

What a day! So proud of our sports day and how everybody in the school is involved all day. Great to welcome family members and the local community into school to share our special day. We had so many ex-students come back & support too, thank you!

RESULTS

Track & Field

- 1st - Trent, 327 points
- 2nd - Mersey, 302 points
- 3rd - Shannon, 251 point
- 4th - Waveney, 222 points

Olympeel Games

- 1st - Mersey, 381 points
- 2nd - Trent, 305 points
- 3rd - Waveney, 294 points
- 4th - Shannon, 268 points



U14 Cricket Hardball

The U14 cricket team have once again had a fantastic summer and can now proudly boast of being COUNTY CHAMPIONS!

The boys finished top of their group with three wins from three games, beating competitive teams from Wymondham College and Notre Dame after being handed a win v KES. The squad was also able to welcome some new additions in a friendly win v a Gresham's 'B' team.

Following this, the U14 team headed to Sprowston Cricket Club for finals day and beat a strong Long Stratton team in the semi-final. Long Stratton set APHS 100 runs to win and the team battled hard to reach their target score with 2.2 overs to play. In the final, we would again have to face Wymondham College who had progressed against Thorpe in the other semi-final. This U14 played the final brilliantly and dominated from the start, being put into bat and setting a difficult 143 for Wymondham to chase. This total was too much to ask for our opponents who had to endure a fantastic bowling and fielding performance from our talented team.

The U14 cricket success in their second year of school hardball cricket is very pleasing and we have built on the outstanding work from last year. Well done to Rhys L, Hayden L, Arthur D, Arthur VA, Freddie G, Seb P, Austin M, Oliver B, Luke B, Alexi E, Finn MN, Charlie L, Will S, Archie R, Tilly F, Milo M, Harry H, Josh A and Henry B. 5 wins from 5 games is an outstanding return and we look forward to another successful cricket season next year!

Alex P (Year 8)

Alex continues to go from strength to strength with his swimming and can proudly say he was a regional finalist in 200m butterfly. Beating off competition from swimmers from Essex, Suffolk, Norfolk, Cambridgeshire, Bedfordshire and Hertfordshire, Alex you once again did your family and all at APHS proud. Keep working hard, you are a superstar!



Hockey update:

As mentioned previously in our newsletter, Hockey at APHS is growing. We now have a good number of students playing regularly outside of school. Austin Mc and Rufus F have taken their Hockey to another level by getting through to the National Final with their North Norfolk Hockey team. A huge achievement and we are very proud of both boys at APHS.

We are looking forward to the Hockey tournaments and fixtures when we return in September, with the girls looking to start their Hockey off from the start of November.

Rounder's Matches:

Alderman Peel High Schools' Rounders club has been well attended this summer across all years. We have managed to travel to Reepham with a year 9 girls' team and a year 9/10 mixed team. The year 9 girl's team were successful in beating both Reepham and Aylsham in the fixture and the Year 9/10 team narrowly lost to Reepham.

Reepham then travelled to APHS a couple of weeks later bringing a Year 8 girls' team and a Year 9 mixed team. After waiting for the torrential rain to stop both teams secured a win against Reepham and there was some superb batting on display from the APHS teams.



Ella G (Year 10)

Ella had a fruitful experience at the East Anglian Championships in Cambridge, smashing her personal best times in 200m (26.6s) and 100m (12.89s). Not only are these outstanding times but they also broke her club (Ryston Runners) records for both 100m & 200m. Ella had already performed well at the Norfolk Schools Athletics Championships to secure a 2nd in the 100m and 3rd in the 200m. Perfect timing for the upcoming school Athletics events and of course sports day! #thisgirlcan



Edward M (Year 10)

Ed took part in his first Triathlon recently at the Norwich triathlon in Whitlingham Broad. Taking part in the sprint Triathlon and lining up alongside 207 other competitors to race, Ed was feeling particularly nervous. The Triathlon involved a 750m swim, 18k bike and 5k run and Ed performed magnificently.

After a positive swim, and in 6th place, Ed biked hard from the off trying not to lose any time, he averaged a speed of 20mph and kept himself in a good position for the final part of the race. Pushing hard though on a very slow gravel and trail course, Ed ran an impressive 18:40s 5k, which was the 3rd fastest time overall. Ed finished in 6th place overall and 2nd in the U18 age category and now has the desire to push on as a triathlete!

Below is a short summary from Ed; "It confirmed to me that my ambition to become a professional triathlete is the right one. Now I'm going about the right steps to make that dream come true, I'm working hard to get the qualifying times to make the Regional Tri academy which is a step closer to getting into the GB team. I'm also approaching companies for sponsorship and saving work money to get a fast bike". If anyone knows of any support that could come Ed's way please make contact with Mr Brett at the school, there are not many people who will work harder than this young man to achieve his dreams!



Eli C (Year 10)

Congratulations to Eli who has successfully made the cut and been selected for the U16 Leicester Tigers Development Player Programme (DPP) next year. This is on top of recently being elected Deputy Head Boy at the school and is fully deserved after many years of setting himself the highest of standards, well done Eli!

Dylan C (Year 10)

Dylan's U15 Mundford team were crowned JPL National Champions during a tournament at Warwick University. Well done to the boys for getting to the champions tournament as regional winners - a great weekend of football and experience for Dylan.

Charlie F (Year 10)

Charlie continues to progress as an athlete and secured an impressive Long Jump of 5.27m at the Norfolk Schools Athletics Championships recently. The video of Charlie's jump can be seen on our PE twitter page and it also earned him 1st place in the U17 competition! Keep up the hard work Charlie.

Grace D (Year 7)

Grace D has had some great success this year in Roller Hockey. Grace is a regional Roller Hockey player already and was invited to attend an England Academy training programme in Portugal during Easter and was even chosen as captain. Grace's local team (Kings Lynn Rink Hockey Club U13's) also got through to the final after winning 3 out of 3 games at a recent Roller Hockey event.

Below is an update from Mrs Davey;

For anybody who has never heard of this sport, we describe it as Ice Hockey on Roller Skates. Grace started playing when she was 8 years old after watching her older brother play. She trains every week in King's Lynn with the junior and senior players and travels once a month to train with players from across the country at England National Academy Training. She is currently Captain for the Under 13 team and plays in the Under 15 team as well. Both these teams are now entering a tournament for a place in the Challenge Cup Final and she has also been selected to play in a Junior Girls team in the Eastern Counties Cup Final Day in July.



Last season she was loaned out to Soham Club Under 11 team who came 2nd in the league. She also played for King's Lynn Under 13. She was selected to play and captain the Under 11 team for the county in the Regional Games (which she was 2nd highest goal scorer in the country at that age). Grace has been on England Academy Training trips to Portugal the first was just before Lockdown and then again in 2021, This year Grace got the opportunity to travel again to Santa Maria da Feira in Portugal over the Easter Holidays for a week's training. The trip consisted of 2 training sessions during the day and in the evening traveling to clubs in the region to play against their young teams. The final two days of the trip the local club put on an Easter Tournament which England played in. Grace captained the U11 team and was also asked to play for the U13 team (which she ended up being 1 of the starting 4 players). Both the U11 and U13 teams came second in the tournament.

Next season she will again be in the King's Lynn U13 team and U15 team. She will hopefully be selected to trial for the region for both mixed and female teams. Her dreams are to play for the club at Premiership Level and to be a part of the England squad. She would also like to play professional hockey in Europe.

Redgate Rangers U12

In Year 7 we have some talented footballers who have had a great season for their grassroots team. Winning promotion from the Championship by winning the league, the boys progress onto 11 a-side in the top division of Norfolk club football. On top of this, the team also won a recent summer tournament to add to their collections of medals!

Well done to Theo L, Sam F, Charlie K and Cody G.



Cluster Sports

Competition results

Monday 15th May 2023
Swimming Gala winners -
Burnham Market Primary School

Monday 22nd May 2023
Tri-Golf winners - Langham
Village School

Monday 12th June 2023
Mini Tennis winners - Langham
Village School

Monday 26th June 2023
Kwik Cricket winners - Burnham
Market Primary School

NNSSP Partnership Games

On Monday 19th June, a number of our year 7 and 8 students were chosen to participate in the NNSSP Partnership Games hosted at UEA. Students were chosen to represent APHS for one of 5 activities. There were the competitive events which included Quadkids Athletics, Basketball and Girls Football and non-competitive activities which included Rock Climbing and Zumba. APHS came away finishing 2nd place in both Quadkids Athletics and Girls Football and 3rd place in Basketball. It was an exceptional day with great commitment and courage shown by all students, who thoroughly enjoyed themselves!



U14 Touch Rugby event

A mixed-gender team of Year 9's took up the opportunity to be introduced to a new fast-paced game of Touch Rugby at the Aylsham Sport Hub.

They got off to a flyer against Stalham High School, before facing Aylsham High School and Fakenham Academy, both schools had experienced the rules earlier in the school year and the APHS team did well to only lose by one try in both encounters.

Due to the nature and intensity of the sport with very little respite the boys and girls did well to finish the day with a draw against Springwood High School.



Ski Trip

Over the Easter holidays 108 students and 14 members of staff took off to Tonale (Italy) for some time skiing up in the mountains. This was a record-breaking number for APHS trip and it was an absolute pleasure and privilege taking away such a fantastic set of students.

The week consisted of glorious mornings skiing in the mountains, followed by a number of fun-filled evenings which involved activities such as a quiz, a disco and a trip for pizza and ice-cream. Throughout the time away, the students were all absolutely outstanding and received nothing but continuous praise from transport staff, resort members and their skiing instructors and were a real credit to themselves and APHS.

A big THANK YOU to all those involved who made this a trip to remember!

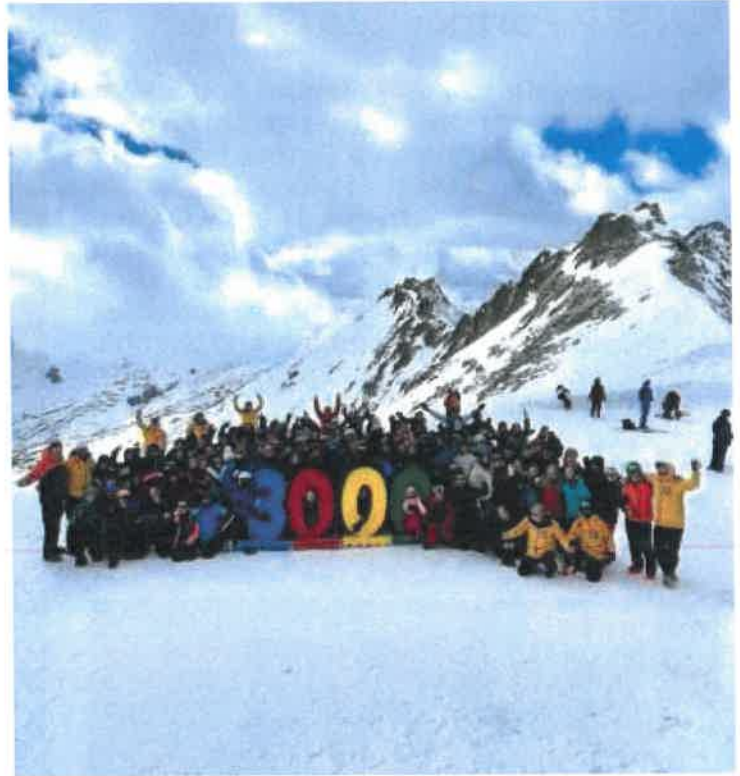

U15 Cricket Hardball

It has been a busy summer of Cricket here at Alderman Peel High School and following on from the success of the U14 team winning the County Shield, the U15 followed suit by winning the State School County Championship!

The U15 team qualified for the County final after topping Group B after a convincing win against Reepham, before some closer wins against Wymondham High and Framingham Earl. Furthermore, the squad had a bit of a warm-up match ahead of the final with some new additions in a competitive fixture versus a Gresham's 'B' team.

Facing a Wymondham College team in a final for the second time within a week, APHS got off to a great start with two maiden overs from Eli C and R Lough respectively. It was not too long until the opening batsman settled into their stride, however controlled bowling and organised fielding help to keep the run rate low. Despite some late wickets, including an important run-out by H Lough, Wymondham College set a challenging score of 133 runs to win.

Opening APHS batters R Lough and Arthur vA started strongly averaging almost a run a ball before both lost their wicket in the 7th over. This saw D Coslett and captain, Eli C enter the fray. Some hard-hitting boundaries kept the chase promising, including a monster 6 from Dylan, who finished his innings on 32 off 25 balls. Some further aggressive batting and additional boundaries were added by Nathan R, who was partnered with some sensible and composed batting from Hayden L. These two boys safely saw the team to victory with an over to spare!

A great team effort and fitting reward to the Year 10's who will not have the chance to take part in any Cricket competitions next summer, due to a busy summer of exams. As for the Year 9's in the squad, many of them are now Double County Champions! The team have been a delight to manage and all at APHS are so very proud of their achievements. Alderman Peel High School are 100% on the Norfolk Cricketing map and a force to be reckoned with by others.



Wensum vs Vikings Schools Representative Matches

Following a number of Development Rugby Days at North Walsham Rugby Club, Scottow Park plenty of Year 7-9 APHS male and female Rugby players were selected to represent a Wensum Trust Representative team against a Vikings Representative team on Friday 31st March 2023. APHS students alongside Hellesdon and Acle pupils gave a very good account of themselves, particularly in the Year 8 and Year 9 boys age groups.

U16 Rugby - State School County Cup final

Knockout wins against a Gresham's 'B' side, Wymondham College 'B' team and a nail-biting semi-final victory over Framingham Earl saw the U16 team qualify for the County Cup final for the first time. The final was never going to be an easy task against an organised Wymondham High side who many play together at club level and who had won competitions in previous years. The task was made even more challenging following an early try to our opposition. The wet conditions continued to make it tricky for APHS to build many meaningful attacks amongst our backs, however the tackling of the team and effort levels were outstanding throughout and despite the 27-0 scoreline, the boys should all feel very proud in the fact that they could walk off the field of play having left everything out there. It has been a pleasure to witness many of this team develop their skills and game throughout their five years at the school and I hope some of them continue to play the sport at club level for years to come.



Leicester Tigers Trip

On Saturday 6th May a number of committed Rugby players were rewarded with the opportunity to see Leicester Tigers take on Harlequins in the final match of the Gallagher Premiership season at Welford Road Stadium.

With Tigers place in the semi-finals already confirmed we had feared the match could become a bit of a dead rubber, however it was sparked into life following a controversial red card given to Chris Ashton just a couple of minutes before half-time. Despite being down to 14 players for all of the second half, Tigers refused to lay down and clawed their way back into the game, but were unable to force the win in the dying seconds of the game (losing it 17-20).

All supporters were invited onto the pitch after the final whistle and many of the students managed to meet the players and get various garments signed by them.

Thank you to Mr Leverton for accompanying Mr Wilding and the boys on the trip.



Celebration of Sport Awards

Students, parents, staff, governors and local sponsors celebrated sporting commitment and achievements at Alderman Peel High School's annual Celebration of Sport Awards Evening on Thursday 30th March 2023.

The evening commenced with a fantastic gymnastics performance, before Ed M, Lily R, Alexia C and Maddy R took to the stage for a motivating opening address. We then welcome our Guest of Honour, Tom Youngs onto the stage, who spoke to a packed audience about the importance of hard-work, resilience, accepting step-backs and looking to learn from them.

The theme this year was based around the Indiana Jones movies, with the slogan 'The Sporting Adventure of your Life' and towards the end of the night, the audience was kept entertained through the terrific videography skills from the talented James Wayland.

All nominees for the evening received a certificate, while winners receiving a glass trophy. Below is a list of the winners of the individual sporting awards for commitment and achievement.

SPORT	Recognition of Outstanding Commitment	Excellence and Outstanding Achievement
Table Tennis	Robert S	George W
Rugby Union	Oliver R	Eli C
Tennis	Charlie S	
Hockey	Yvie M	Archie R
Athletics	Finn S	Ella G
Swimming	Dylan L	Aiden F
Judo	Adelaide C	Honey H
Dodgeball	Austin Mc	
KS3 Netball	Matilda S	Poppy T
KS4 Netball	Sydney H	Ella G
Girls Football	Zenepe F	Izzy N
KS3 Football	Luke B	Ewan M
KS4 Football	Finn S	Ted H
Gymnastics	Hazel H	Jemima C
Basketball	Arthur L	Lando C
Equestrian		Mollie S
Cricket	Freddie G	Rhys L
Cross Country	Charlie F	Ed M
Dance	Esmay O	Lily F
GCSE PE Theory	Skye F	Jemima C
GCSE PE Practical	George W	Lily F & Ted H
OCR Sport Studies	Tommy Y	Finn S

Celebration of Sport Awards

After a short interval the main award winners were revealed with them receiving a silver salver and wooden plaque

MAIN AWARD	WINNER(S)
GIRLS EXEMPLARY ATTITUDE TO PE	Alexia C
BOYS EXEMPLARY ATTITUDE TO PE	Oliver B
ENDEAVOUR IN GIRLS SPORT	Poppy T
ENDEAVOUR IN BOYS SPORT	Ed M
SIBLINGS EXCEPTIONAL COMMITMENT	Nell H, Joe H & Ted H
INSPIRE TO ASPIRE LEADER	Harry C
LEADER OF THE FUTURE	Ted H
GIRLS COMMITMENT TO APHS SPORT	Lily R & Maddy R
BOYS COMMITMENT TO APHSSPORT	Austin Mc
GIRLS OVERALL OUTSTANDING SPORTING ACHIEVEMENT	Sydney H
BOYS OVERALL OUTSTANDING SPORTING ACHIEVEMENT	Eli C
PARENTS SPECIAL RECOGNITION	Vicky Etheridge & Ash Murray
THE CHRIS COUBROUGH UNSUNG HERO	Tommy Y
THE PHILIP PLATTEN TEAM OF THE YEAR	U13 Cricket Team
THE KIRSTY HARDMAN SPIRIT OF SPORT AWARD	George W
SPORTS PERSONALITY OF THE YEAR	Finn S & Hazel H

Photos from the evening can be seen and purchased from the following website:

<https://photos.ido-photography.co.uk/gallery/21057943/>

The password to view them is: APHS2023

The PE Department would publically like to thank all those within the local community who supported and sponsored the evening as well as the Wensum Trust, Leadership Team and governors.



Celebration of Sport Awards



Our Partners



HAYES + STORR
Solicitors
& Notaries



FAKENHAM GARDEN CENTRE
For all your gardening needs
Plus...
Pets & Aquatics
Coffee Shop
Giftware
Tel: 01328 863380
www.fakenhamgardencentre.co.uk



DOM SOFTWARE
Application Development, System
Integration, Database Solutions & More
www.dom-software.net
Tel: 0330 350 1284
Gogo Tech Partner
Microsoft
CERTIFIED



**swimming
health & fitness**
www.sportapeel.co.uk



NeilThompsonBoats



Basketball
in the community



Bailey Bird & Warren
Local Estate Agents, Valuers & Surveyors
We're proud to sponsor
APHS
awards evening for our
NEW WELLS OFFICE
Tel: Wells (01328) 641048
Tel: Fakenham (01328) 864761
E: office@baileybirdandwarren.co.uk

THE ARTS SOCIETY GLAVEN VALLEY



WELLS-NEXT-THE-SEA
FRENCH'S
FISH SHOP
SINCE 1921



Fakenham
RACECOURSE



THE COPPER KETTLE
HUNSTANTON

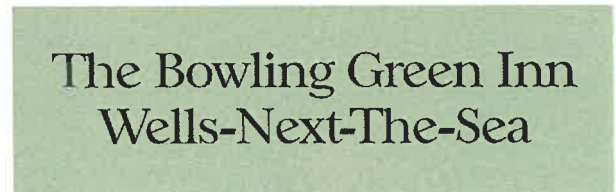

The Bowling Green Inn
Wells-Next-The-Sea



PEELINGS COACHES
The Garage, Clay Hill
Tittleshall, Kings Lynn
Norfolk. PE32 2RQ
info@peelings-coaches.co.uk
01328 701531

HOLKHAM



Charlotte's Sharks
swim school

We are part of ...

WENSUM TRUST

FOR CHILDREN, FAMILIES AND COMMUNITIES

W: www.aldermanpeel.norfolk.sch.uk



AldermanPeelHigh



@AldermanHigh